

365C-30EXT
365C-30EXT-T

365C-30INT
365C-30INT-T

365C-45EXT
365C-45EXT-T



BID SPECIFICATIONS

STANDARD

- * LED LIGHTING STANDARD
- * GALVANIZED STEEL CHASSIS CONSTRUCTION
- * INSULATED WITH DENSE NON-CFC ECOLOGIC POLYURETHANE FOAM
- * INSIDE STRUCTURE MADE OF HIGH GLOSS 304 STAINLESS STEEL
- * DIGITAL DIAGNOSTIC CONTROL SYSTEM WITH PROGRAMMABLE DEFROSTING
- * DIGITAL HUMIDITY CONTROL
- * REAR SLIDING PLEXIGLAS DOOR
- * AIR-COOLED CONDENSING UNIT
- * MULTIPLEXING CAPABILITY WITH PASTRY, DELI CHOCOLATE AND HOT CASE APPLCIATIONS

- * UNIQUE FAN ASSISTED AIRFLOW DESIGN
- * TILT BACK FRONT GLASS
- * ALL TEMPERED, DOUBLE PANE HEATED GLASS ON FRONT AND SIDES
- * SIDE PANELS IN SILVER PAINTED FINISH
- * FRONT LOWER GLASS FACIA COLORS

(GLASS IS BACK PAINTED):



- * DISPLAY CASE(S) TO BE SHIPPED FULLY ASSEMBLED
- * THE STANDARD LIMITED WARRANTY INCLUDES:
5 YEAR COMPRESSOR; 1 YEAR PARTS; 90 DAYS LABOR
- * DISPLAY CASE(S) TO BE LABORATORY CERTIFIED AS DESCRIBED

OPTIONAL

- * CASTERS
- * GRANITE WORK SURFACE (OPERATOR SIDE)
- * REMOTE CONDENSING UNIT
- * SIDE PANELS IN CUSTOM COLOR OTHER THAN STOCK SILVER FINISH
- * END PANELS

- * SIDE PANELS PAINTED IN A GLOSSY FINISH

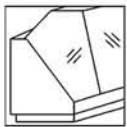

STANDARD END PANEL



NO DECORATIVE END PANEL AVAILABLE IN 365

365 Chocolate Curved Refrigerated Case Technical Specifications

Model no.	Factory Code	Case Height	*Case Length	Case Depth	Crated Weight (lb)	Line Voltage	Breaker Size	Amp Draw	Working Temp F	Compressor Size
365C-30EXT	RP 30A	49.25"	*A & B*	47.44"	1020	115/1/60	20amps	10	55	1/3 HP
365C-30EXT-T	RP 30A	55.25"	*A & B*	47.44"	1020	115/1/60	20amps	10	55	1/3 HP
365C-30INT	RP 30C	49.25"	*A & B*	47.44"	1020	115/1/60	20amps	10	55	1/3 HP
365C-30INT-T	RP 30C	55.25"	*A & B*	47.44"	1020	115/1/60	20amps	10	55	1/3 HP
365C-45EXT	RP 45A	49.25"	*A & B*	47.44"	1020	115/1/60	20amps	10	55	1/3 HP
365C-45EXT-T	RP 45A	55.25"	*A & B*	47.44"	1020	115/1/60	20amps	10	55	1/3 HP

T = Tall (55.25" HIGH)

* Case lengths are specified with standard end panels

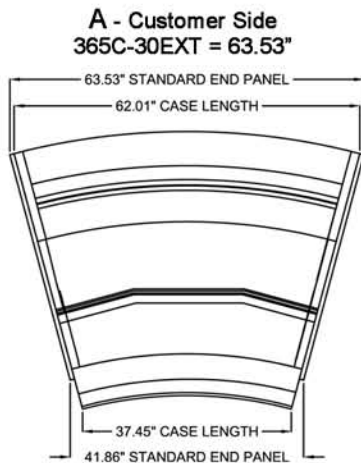

B - Server Side
365C-30EXT = 41.86"

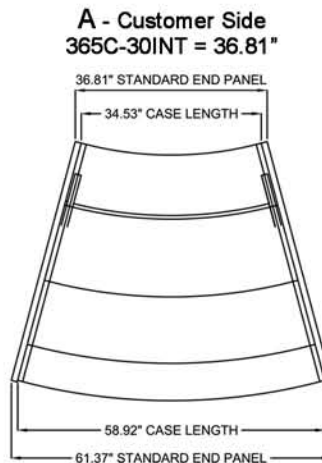

B - Server Side
365C-30INT = 61.37"

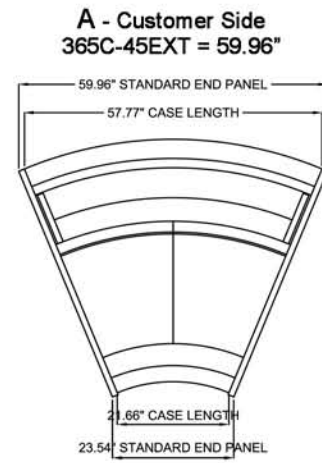

B - Server Side
365C-45EXT = 23.54"

PLAN / TOP VIEWS OF CORNER CASES

LISTINGS:

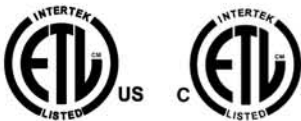

ELECTRICAL CONNECTION:

Display cases are shipped with applicable junction box for hardwired installation
Options exist for several NEMA configurations
Plug and/or receptacle configurations are at the discretion of the electrical installer

NOTE:

Required ambient conditions: 75°F; 55% RH
Drawing and Specifications are subject to change without notice

CLABO North America, LLC
33300 Central Avenue
Union City, CA 94587 USA
PH 800.672.2784
FAX 510.441.0401
<http://www.otl-usa.com>