

365D-30EXT  
365D-30EXT-T

365D-30INT  
365D-30INT-T

365D-45EXT  
365D-45EXT-T



### BID SPECIFICATIONS

STANDARD

- \* LED LIGHTING STANDARD
- \* GALVANIZED STEEL CHASSIS CONSTRUCTION
- \* INSULATED WITH DENSE NON-CFC ECOLOGIC POLYURETHANE FOAM
- \* INSIDE STRUCTURE MADE OF HIGH GLOSS 304 STAINLESS STEEL
- \* DIGITAL DIAGNOSTIC CONTROL SYSTEM WITH PROGRAMMABLE DEFROSTING
- \* REAR SLIDING PLEXIGLAS DOOR
- \* AIR-COOLED CONDENSING UNIT
- \* MULTIPLEXING CAPABILITY WITH PASTRY, DELI, CHOCOLATE AND HOT CASE APPLICATIONS

- \* UNIQUE FAN ASSISTED AIRFLOW DESIGN
  - \* TILT BACK FRONT GLASS
  - \* ALL TEMPERED, DOUBLE PANED HEATED GLASS ON FRONT AND SIDES
  - \* SIDE PANELS IN SILVER PAINTED FINISH
  - \* FRONT LOWER GLASS FACIA COLORS (GLASS IS BACK PAINTED):
- |        |           |       |       |
|--------|-----------|-------|-------|
|        |           |       |       |
| SILVER | CHAMPAGNE | BROWN | WHITE |
- \* DISPLAY CASE(S) TO BE SHIPPED FULLY ASSEMBLED
  - \* THE STANDARD LIMITED WARRANTY INCLUDES:  
5 YEAR COMPRESSOR; 1 YEAR PARTS; 90 DAYS LABOR
  - \* DISPLAY CASE(S) TO BE LABORATORY CERTIFIED AS DESCRIBED

OPTIONAL

- \* CASTERS
- \* GRANITE WORK SURFACE (OPERATOR SIDE)
- \* REMOTE CONDENSING UNIT
- \* SIDE PANELS IN CUSTOM COLOR OTHER THAN STOCK SILVER FINISH
- \* END PANELS

- \* SIDE PANELS PAINTED IN A GLOSSY FINISH



STANDARD END PANEL



NO DECORATIVE END PANEL AVAILABLE IN 365

## 365 Deli Refrigerated Curved Case Technical Specifications

Same as Pastry, no drawer

Model no.	Factory Code	Case Height	*Case Length	Case Depth	Crated Weight (lb)	Line Voltage	Breaker Size	Amp Draw	Working Temp F	Comp. HP
365D-30EXT	RVS 30A	49.25"	*A & B*	47.44"	1020	115/1/60	20amps	10	41	1/3 HP
365D-30EXT-T	RVS 30A	55.25"	*A & B*	47.44"	1020	115/1/60	20amps	10	41	1/3 HP
365D-30INT	RVS 30C	49.25"	*A & B*	47.44"	1020	115/1/60	20amps	10	41	1/3 HP
365D-30INT-T	RVS 30C	55.25"	*A & B*	47.44"	1020	115/1/60	20amps	10	41	1/3 HP
365D-45EXT	RVS 45A	49.25"	*A & B*	47.44"	844	115/1/60	20amps	10	41	1/3 HP
365D-45EXT-T	RVS 45A	55.25"	*A & B*	47.44"	844	115/1/60	20amps	10	41	1/3 HP

T = Tall (55.25" HIGH)

\* Case lengths are specified with standard end panels

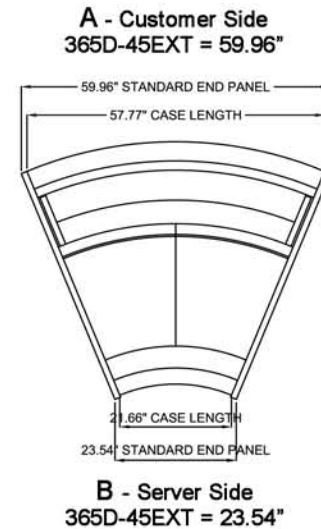
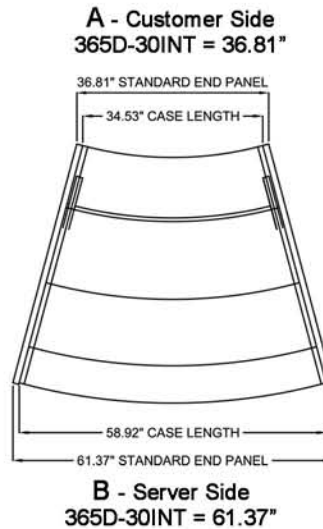
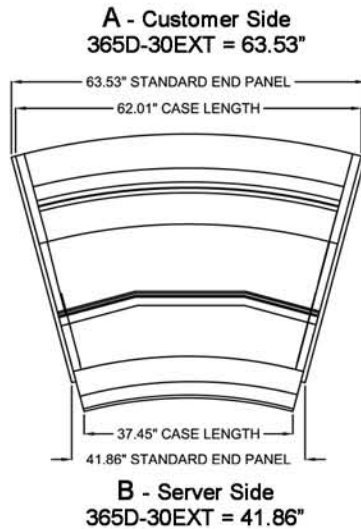

### PLAN / TOP VIEWS OF CORNER CASES

#### LISTINGS:



#### ELECTRICAL CONNECTION:

Display cases are shipped with applicable junction box for hardwired installation  
Options exist for several NEMA configurations  
Plug and/or receptacle configurations are at the discretion of the electrical installer

#### NOTE:

Required ambient conditions: 75°F; 55% RH  
Drawing and Specifications are subject to change without notice

CLABO North America, LLC  
33300 Central Avenue  
Union City, CA 94587 USA  
PH 800.672.2784  
FAX 510.441.0401  
<http://www.otl-usa.com>