

365D-43
365D-43T

365D-64
365D-64T

365D-85
365D-85T



BID SPECIFICATIONS

STANDARD

- * LED LIGHTING STANDARD
- * GALVANIZED STEEL CHASSIS CONSTRUCTION
- * INSULATED WITH DENSE NON-CFC ECOLOGIC POLYURETHANE FOAM
- * INSIDE STRUCTURE MADE OF HIGH GLOSS 304 STAINLESS STEEL
- * DIGITAL DIAGNOSTIC CONTROL SYSTEM WITH PROGRAMMABLE DEFROSTING
- * REAR SLIDING DOUBLE PANE GLASS DOOR
- * AIR-COOLED CONDENSING UNIT
- * MULTIPLEXING CAPABILITY WITH PASTRY, DELI, CHOCOLATE AND HOT CASE APPLICATIONS

- * UNIQUE FAN ASSISTED AIRFLOW DESIGN
 - * TILT BACK FRONT GLASS
 - * ALL TEMPERED, DOUBLE PANED HEATED GLASS ON FRONT AND SIDES
 - * SIDE PANELS IN SILVER PAINTED FINISH
 - * FRONT LOWER GLASS FACIA COLORS
(GLASS IS BACK PAINTED):
- | | | | |
|--|---|---|---|
|  |  |  |  |
| SILVER | CHAMPAGNE | BROWN | WHITE |
- * DISPLAY CASE(S) TO BE SHIPPED FULLY ASSEMBLED
 - * THE STANDARD LIMITED WARRANTY INCLUDES:
5 YEAR COMPRESSOR; 1 YEAR PARTS; 90 DAYS LABOR
 - * DISPLAY CASE(S) TO BE LABORATORY CERTIFIED AS DESCRIBED

OPTIONAL

- * CASTERS
- * GRANITE WORK SURFACE (OPERATOR SIDE)
- * REMOTE CONDENSING UNIT
- * SIDE PANELS IN CUSTOM COLOR OTHER THAN STOCK SILVER FINISH
- * REAR AIR INTAKE AND DISCHARGE
- * END PANELS

- * SIDE PANELS PAINTED IN A GLOSSY FINISH



STANDARD END PANEL



NO DECORATIVE END PANEL AVAILABLE IN 365

365 Deli Refrigerated Case Technical Specifications

Same as Pastry, no drawer

Model no.	Factory Code	Case Height	*Case Length	Case Depth	Crated Weight (lb)	Line Voltage	Breaker Size	Amp Draw	Working Temp F	Comp. HP
365D-43	RVS 2M	49.25"	43.08"	47.44"	690	115/1/60	20amps	10	41	1/3 HP
365D-43T	RVS 2M	55.25"	43.08"	47.44"	734	115/1/60	20amps	10	41	1/3 HP
365D-64	RVS 3M	49.25"	63.74"	47.44"	844	115/1/60	20amps	11	41	1/2 HP
365D-64T	RVS 3M	55.25"	63.74"	47.44"	888	115/1/60	20amps	11	41	1/2 HP
365D-85	RVS 4M	49.25"	84.41"	47.44"	998	115/1/60	20amps	12	41	3/4 HP
365D-85T	RVS 4M	55.25"	84.41"	47.44"	1042	115/1/60	20amps	12	41	3/4 HP

T = Tall (55.25 HIGH)

* Case lengths are specified with standard end panels

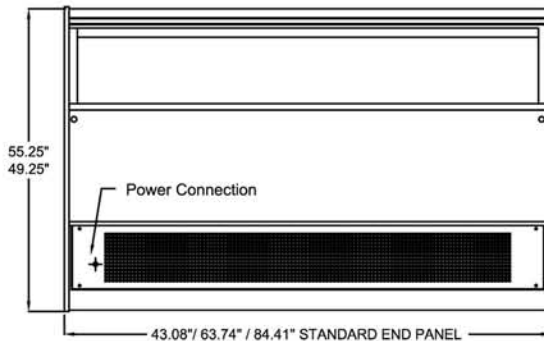
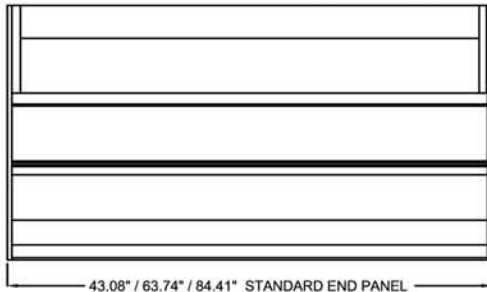

PLAN & REAR VIEW

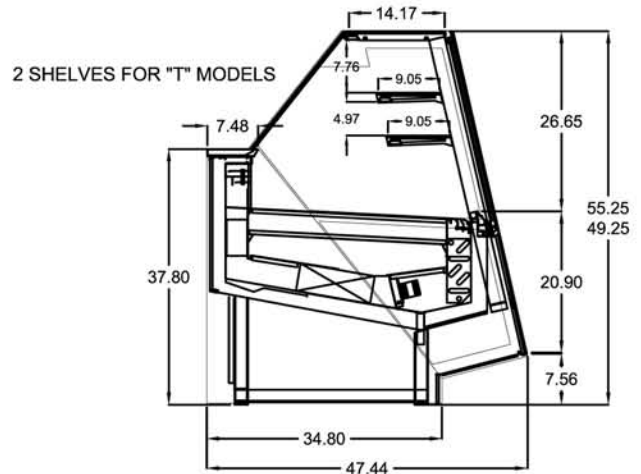

SIDE VIEW

LISTINGS:

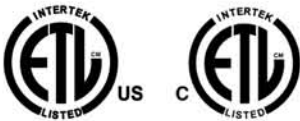

ELECTRICAL CONNECTION:

Display cases are shipped with applicable junction box for hardwired installation
Options exist for several NEMA configurations
Plug and/or receptacle configurations are at the discretion of the electrical installer

NOTE:

Required ambient conditions: 75°F; 55% RH
Drawing and Specifications are subject to change without notice

CLABO North America, LLC
33300 Central Avenue
Union City, CA 94587 USA
PH 800.672.2784
FAX 510.441.0401
<http://www.otl-usa.com>