

365P-30EXT  
365P-30EXT-T

365P-30INT  
365P-30INT-T

365P-45EXT  
365P-45EXT-T



### BID SPECIFICATIONS

STANDARD

- \* LED LIGHTING STANDARD
- \* GALVANIZED STEEL CHASSIS CONSTRUCTION
- \* INSULATED WITH DENSE NON-CFC ECOLOGIC POLYURETHANE FOAM
- \* INSIDE STRUCTURE MADE OF HIGH GLOSS 304 STAINLESS STEEL
- \* DIGITAL DIAGNOSTIC CONTROL SYSTEM WITH PROGRAMMABLE DEFROSTING
- \* REAR SLIDING PLEXIGLASS DOOR
- \* AIR-COOLED CONDENSING UNIT
- \* UNIQUE FAN ASSISTED AIRFLOW
- \* HYDRAULIC TILT BACK FRONT GLASS

- \* ALL TEMPERED, DOUBLE PANE HEATED GLASS ON FRONT AND SIDES

- \* SIDE PANELS IN SILVER PAINTED FINISH

- \* FRONT LOWER GLASS FACIA COLORS

(GLASS IS BACK PAINTED):

SILVER CHAMPAGNE BROWN WHITE

- \* MULTIPLEXING CAPABILITY WITH GELATO, PASTRY, DELI, CHOCOLATE AND HOT CASE APPLICATIONS

- \* DISPLAY CASE(S) TO BE SHIPPED FULLY ASSEMBLED

- \* THE STANDARD LIMITED WARRANTY INCLUDES:  
5 YEAR COMPRESSOR; 1 YEAR PARTS; 90 DAYS LABOR

- \* DISPLAY CASE(S) TO BE LABORATORY CERTIFIED AS DESCRIBED

OPTIONAL

- \* CASTERS
- \* GRANITE WORK SURFACE (OPERATOR SIDE)
- \* REMOTE CONDENSING UNIT
- \* SIDE PANELS IN CUSTOM COLOR OTHER THAN STOCK SILVER FINISH
- \* END PANELS

- \* SIDE PANELS PAINTED IN A GLOSSY FINISH



STANDARD END PANEL



NO DECORATIVE END PANEL AVAILABLE IN 365

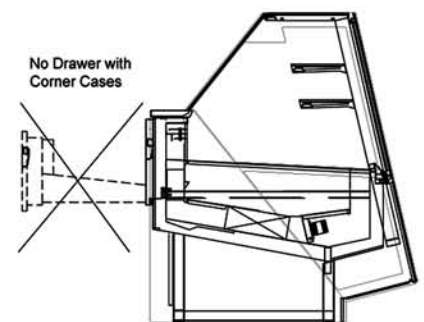

## 365 Pastry Curved Refrigerated Case Technical Specifications

Same as Deli, with drawer

Model no.	Factory Code	Case Height	*Case Length	Case Depth	Crated Weight (lb)	Line Voltage	Breaker Size	Amp Draw	Working Temp F	Comp. HP
365P-30EXT	RVS 30A	49.25"	*A & B*	47.44"	800	115/1/60	20amps	10	41	1/3 HP
365P-30EXT-T	RVS 30A	55.25"	*A & B*	47.44"	844	115/1/60	20amps	10	41	1/3 HP
365P-30INT	RVS 30C	49.25"	*A & B*	47.44"	800	115/1/60	20amps	10	41	1/3 HP
365P-30INT-T	RVS 30C	55.25"	*A & B*	47.44"	844	115/1/60	20amps	10	41	1/3 HP
365P-45EXT	RVS 45A	49.25"	*A & B*	47.44"	668	115/1/60	20amps	10	41	1/3 HP
365P-45EXT-T	RVS 45A	55.25"	*A & B*	47.44"	712	115/1/60	20amps	10	41	1/3 HP

T = Tall (55.25" HIGH)

\* Case lengths are specified with standard end panels

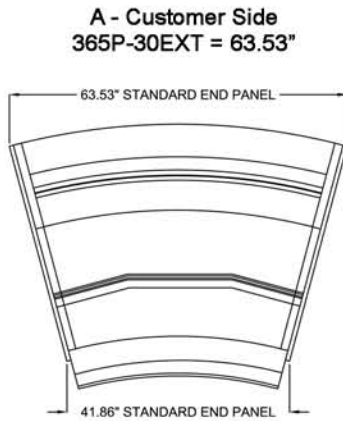

B - Server Side  
365P-30EXT = 41.86"

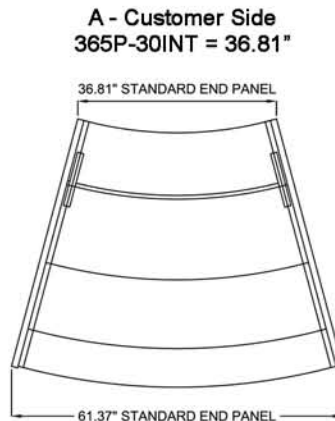

B - Server Side  
365P-30INT = 61.37"

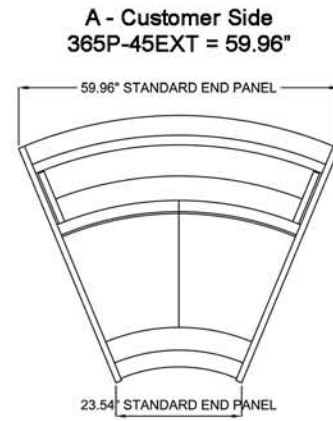

B - Server Side  
365P-45EXT = 23.54"

### PLAN / TOP VIEWS OF CORNER CASES

#### LISTINGS:



#### ELECTRICAL CONNECTION:

Display cases are shipped with applicable junction box for hardwired installation  
Options exist for several NEMA configurations  
Plug and/or receptacle configurations are at the discretion of the electrical installer

#### NOTE:

Required ambient conditions: 75°F; 55% RH  
Drawing and Specifications are subject to change without notice

CLABO North America, LLC  
33300 Central Avenue  
Union City, CA 94587 USA  
PH 800.672.2784  
FAX 510.441.0401  
<http://www.otl-usa.com>