

365P-43
365P-43T

365P-64
365P-64T

365P-85
365P-85T



BID SPECIFICATIONS

STANDARD

- * LED LIGHTING STANDARD
- * GALVANIZED STEEL CHASSIS CONSTRUCTION
- * INSULATED WITH DENSE NON-CFC ECOLOGIC POLYURETHANE FOAM
- * INSIDE STRUCTURE MADE OF HIGH GLOSS 304 STAINLESS STEEL
- * DIGITAL DIAGNOSTIC CONTROL SYSTEM WITH PROGRAMMABLE DEFROSTING
- * REAR SLIDING PLEXIGLASS DOOR
- * AIR-COOLED CONDENSING UNIT
- * UNIQUE FAN ASSISTED AIRFLOW
- * HYDRAULIC TILT BACK FRONT GLASS

- * ALL TEMPERED, DOUBLE PANE HEATED GLASS ON FRONT AND SIDES
 - * SIDE PANELS IN SILVER PAINTED FINISH
 - * FRONT LOWER GLASS FACIA COLORS (GLASS IS BACK PAINTED):
- | | | | |
|--------|-----------|-------|-------|
| | | | |
| SILVER | CHAMPAGNE | BROWN | WHITE |
- * MULTIPLEXING CAPABILITY WITH GELATO, PASTRY, DELI, CHOCOLATE AND HOT CASE APPLICATIONS
 - * DISPLAY CASE(S) TO BE SHIPPED FULLY ASSEMBLED
 - * THE STANDARD LIMITED WARRANTY INCLUDES:
5 YEAR COMPRESSOR; 1 YEAR PARTS; 90 DAYS LABOR
 - * DISPLAY CASE(S) TO BE LABORATORY CERTIFIED AS DESCRIBED

OPTIONAL

- * REAR SLIDING DOUBLE PANE GLASS DOOR
- * CASTERS
- * GRANITE WORK SURFACE (OPERATOR SIDE)
- * REMOTE CONDENSING UNIT
- * REAR AIR INTAKE AND DISCHARGE
- * SIDE PANELS IN CUSTOM COLOR OTHER THAN STOCK SILVER FINISH
- * END PANELS



STANDARD END PANEL



NO DECORATIVE END PANEL AVAILABLE IN 365

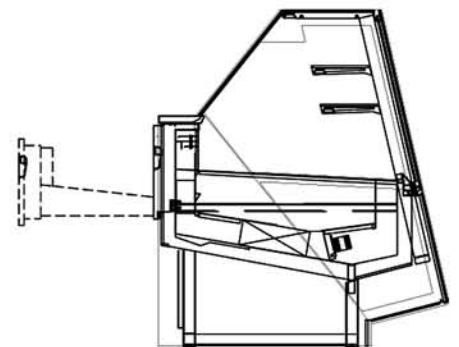

365 Pastry Refrigerated Case Technical Specifications

Same as Deli, with drawer

Model no.	Factory Code	Case Height	*Case Length	Case Depth	Crated Weight (lb)	Line Voltage	Breaker Size	Amp Draw	Working Temp F	Comp. HP
365P-43	RVC 2M	49.25"	43.08"	47.44"	734	115/1/60	20amps	10	41	1/3 HP
365P-43T	RVC 2M	55.25"	43.08"	47.44"	734	115/1/60	20amps	10	41	1/3 HP
365P-64	RVC 3M	49.25"	63.74"	47.44"	888	115/1/60	20amps	11	41	1/2 HP
365P-64T	RVC 3M	55.25"	63.74"	47.44"	888	115/1/60	20amps	11	41	1/2 HP
365P-85	RVC 4M	49.25"	84.41"	47.44"	1042	115/1/60	20amps	12	41	3/4 HP
365P-85T	RVC 4M	55.25"	84.41"	47.44"	1042	115/1/60	20amps	12	41	3/4 HP

T = Tall (55.25" HIGH)

* Case lengths are specified with standard end panels

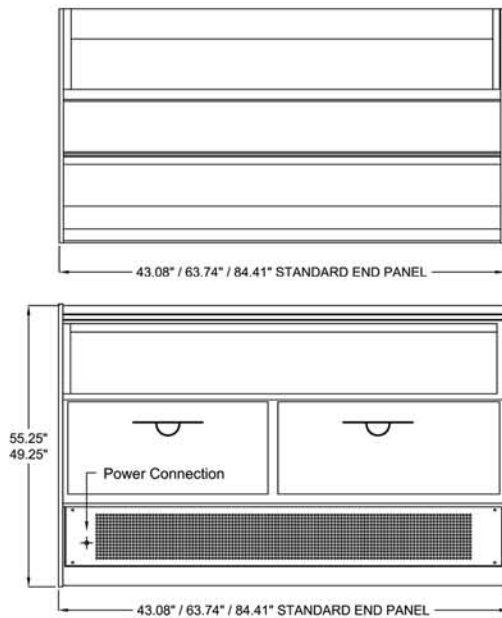

PLAN & REAR VIEW



STANDARD END PANEL



NO DECORATIVE END PANEL AVAILABLE IN 365

2 SHELVES FOR "T" MODELS

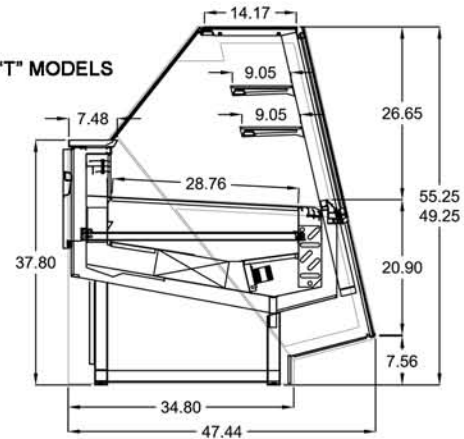

SIDE VIEW

LISTINGS:

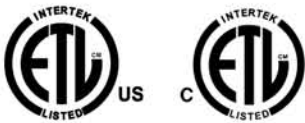

ELECTRICAL CONNECTION:

Display cases are shipped with applicable junction box for hardwired installation
Options exist for several NEMA configurations
Plug and/or receptacle configurations are at the discretion of the electrical installer

NOTE:

Required ambient conditions: 75°F; 55% RH
Drawing and Specifications are subject to change without notice

CLABO North America, LLC
33300 Central Avenue
Union City, CA 94587 USA
PH 800.672.2784
FAX 510.441.0401
<http://www.otl-usa.com>