

CBM40

CBM50

CBM60



BID SPECIFICATIONS

STANDARD

- * DOUBLE PANE HEATED GLASS FRONT AND SIDES
- * HYDRAULIC LIFT UP FRONT GLASS
- * BACK & INSIDE STRUCTURE MADE OF HIGH GLOSS 304 STAINLESS STEEL
- * MULTIPLEXING CAPABILITY WITH GELATO, PASTRY, DELI, CHOCOLATE AND HOT CASE APPLICATIONS
- * GALVANIZED STEEL CHASSIS CONSTRUCTION
- * INSULATED WITH DENSE NON-CFC ECOLOGIC POLYURETHANE FOAM
- * SILVER ANODIZED ALUMINUM FINISH

- * DISPLAY CASE(S) TO BE SHIPPED FULLY ASSEMBLED
- * THE STANDARD LIMITED WARRANTY INCLUDES:
1 YEAR PARTS; 90 DAYS LABOR
- * DISPLAY CASE(S) TO BE LABORATORY CERTIFIED AS DESCRIBED

Easy Delivery

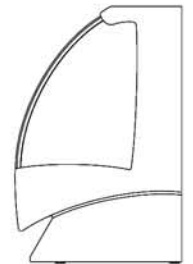

Only 35.25" Deep

OPTIONAL

- * CASTERS
- * DECORATIVE END PANELS

- * SIDE & FRONT PANELS PAINTED IN A GLOSSY FINISH (CASE SHIPS IN BUFF WHITE PRIMER)

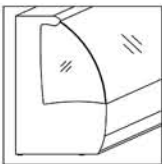

STANDARD END PANEL

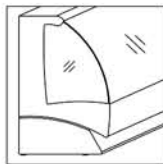

DECORATIVE END PANEL (OPTIONAL)
ADD 1.50" TO TOTAL LENGTH



Italiana Hot - Bain Marie Case Technical Specifications

Model	Height	*Case Length	Depth	Crated Weight (lb)	Line Voltage	Breaker Size
CBM40	54.00"	41.50"	35.25"	320	* 230/1/60	20 amp
CBM50	54.00"	51.50"	35.25"	408	* 230/1/60	20 amp
CBM60	54.00"	61.50"	35.25"	496	* 230/1/60	20 amp

* 3 Phase Available

*Case lengths are specified with standard end panels

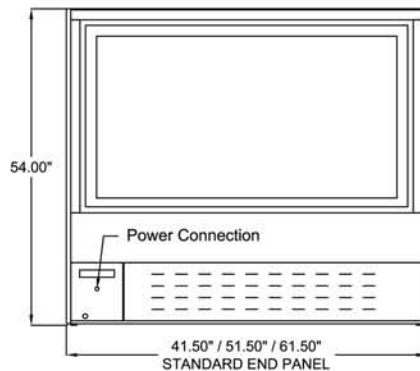
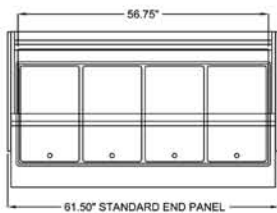
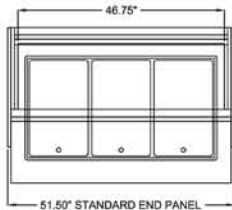
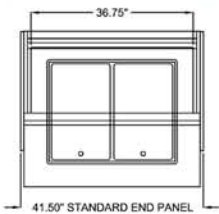

STANDARD END PANEL



DECORATIVE END PANEL (OPTIONAL)

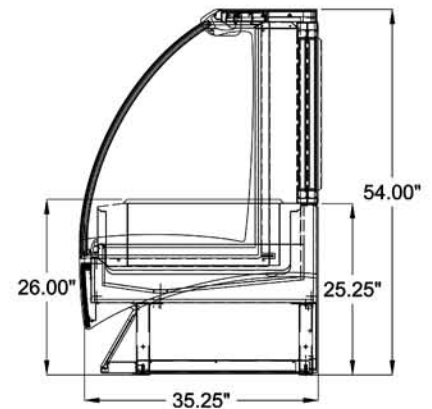

PLAN & REAR VIEW

SIDE VIEW

LISTINGS:



ELECTRICAL CONNECTION:

Display cases are shipped with applicable junction box for hardwired installation
Options exist for several NEMA configurations
Plug and/or receptacle configurations are at the discretion of the electrical installer

NOTE:

Required ambient conditions: 75°F; 55% RH
Drawing and Specifications are subject to change without notice

CLABO North America, LLC
33300 Central Avenue
Union City, CA 94587 USA
PH 800.672.2784
FAX 510.441.0401
<http://www.otl-usa.com>