

SP38

SP56

SP73

SP110



BID SPECIFICATIONS

STANDARD

- * ALL TEMPERED GLASS ON FRONT AND SIDES
- * GALVANIZED STEEL CHASSIS CONSTRUCTION
- * INSULATED WITH DENSE NON-CFC ECOLOGIC POLYURETHANE FOAM
- * INSIDE STRUCTURE MADE OF HIGH GLOSS 304 STAINLESS STEEL
- * STAINLESS STEEL WORK SURFACE
- * DIGITAL DIAGNOSTIC CONTROL SYSTEM WITH PROGRAMMABLE DEFROSTING
- * REAR PLEXIGLASS SLIDING DOORS
- * AIR-COOLED CONDENSING UNIT
- * UNIQUE FAN ASSISTED AIRFLOW DESIGN
- * HYDRAULIC LIFT UP FRONT GLASS
- * REFRIGERATED DECK, NON-REFRIGERATED SHELVES
- * MULTIPLEXING CAPABILITY WITH GELATO, PASTRY, CHOCOALTE AND HOT CASE APPLICATIONS
- * DISPLAY CASE(S) TO BE SHIPPED FULLY ASSEMBLED
- * THE STANDARD LIMITED WARRANTY INCLUDES:
5 YEAR COMPRESSOR; 1 YEAR PARTS; 90 DAYS LABOR
- * DISPLAY CASE(S) TO BE LABORATORY CERTIFIED AS DESCRIBED

OPTIONAL

- * CASTERS
- * GRANITE WORK SURFACE (OPERATOR SIDE)
- * REMOTE CONDENSING UNIT
- * REAR AIR INTAKE AND DISCHARGE
- * DECORATIVE SIDE PANELS
- * SIDE & FRONT PANELS PAINTED IN A GLOSSY FINISH (CASE SHIP IN BUFF WHITE PRIMER)

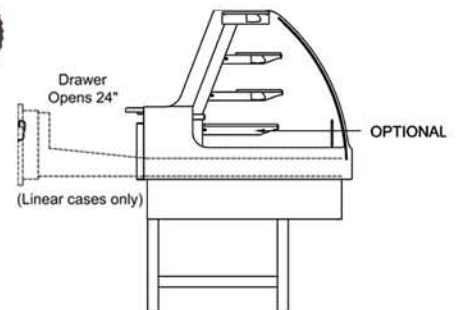

Sacher Pastry Case Technical Specifications

Same as Deli Refrigerated Case, but includes drawer

Updated Model no.	Old Model No.	Factory Code	Case Height	*Case Length	Case Depth	Crated Weight (lb)	Line Voltage	Breaker Size	Amp Draw	Working Temp F	Comp.H.P.
SP38	C87S-3SC	RVC 2M	55.50"	37.16"	41.61"	840	115/1/60	20amps	10	38	1/3 HP
SP56	C87S-5SC	RVC 3M	55.50"	55.42"	41.61"	1245	115/1/60	20amps	11	38	1/2 HP
SP73	C87S-7SC	RVC 4M	55.50"	73.34"	41.61"	1566	115/1/60	20amps	11	38	1/2HP
SP110	C87S-9SC	RVC 6M	55.50"	109.95"	41.61"	2127	115/1/60	20amps	12	38	3/4 HP

*Case lengths are specified with standard end panels

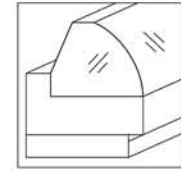

STANDARD END PANEL



DECORATIVE END PANEL

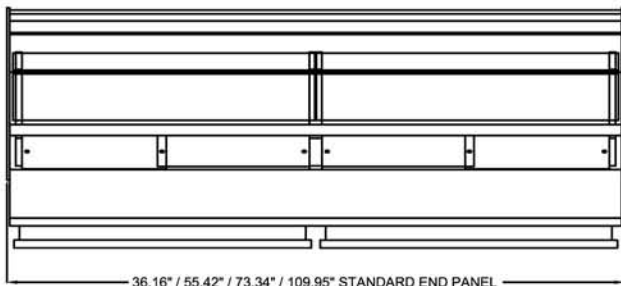

36.16" / 55.42" / 73.34" / 109.95" STANDARD END PANEL

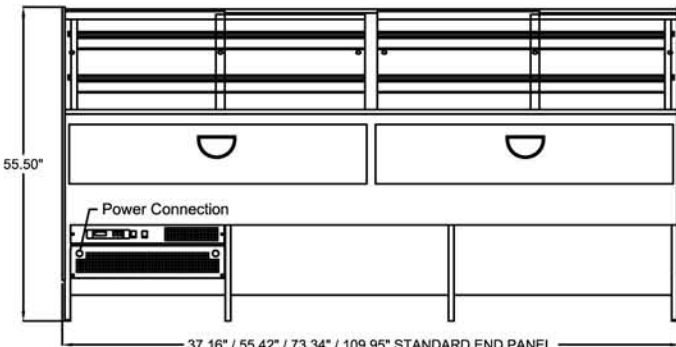

37.16" / 55.42" / 73.34" / 109.95" STANDARD END PANEL

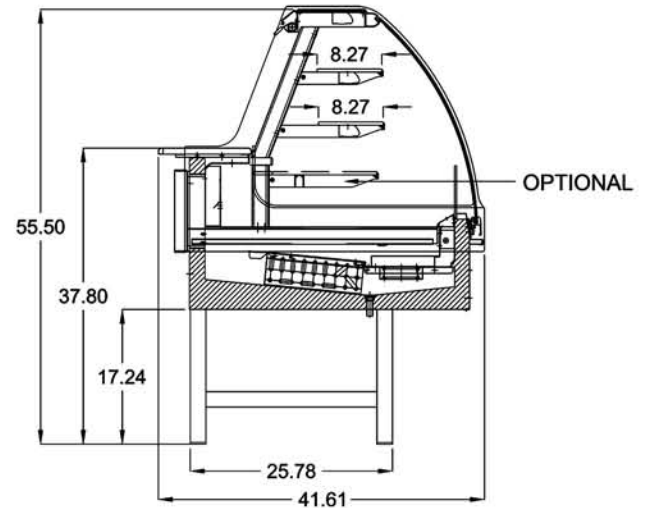

OPTIONAL

PLAN & REAR VIEW

SIDE VIEW

LISTINGS:



ELECTRICAL CONNECTION:

Display cases are shipped with applicable junction box for hardwired installation
Options exist for several NEMA configurations
Plug and/or receptacle configurations are at the discretion of the electrical installer

NOTE:

Required ambient conditions: 75°F; 55% RH
Drawing and Specifications are subject to change without notice

CLABO North America, LLC
33300 Central Avenue
Union City, CA 94587 USA
PH 800.672.2784
FAX 510.441.0401
<http://www.otl-usa.com>