

TH44 TH65 TBM65



### BID SPECIFICATIONS

S  
T  
A  
N  
D  
A  
R  
D

- \* CS - DRY WARMED TOP ON STAINLESS STEEL BASIN
- \* CBM - HOT WELLS FOOD WARMER
- \* TEMPERED GLASS ON FRONT AND SIDES
- \* MADE OF STAINLESS STEEL
- \* MULTIPLEXING CAPABILITY WITH GELATO, PASTRY, DELI, CHOCOLATE AND HOT CASE APPLICATIONS
- \* SILVER ANODIZED ALUMINUM TRIM
- \* DISPLAY CASE(S) TO BE SHIPPED FULLY ASSEMBLED
- \* THE STANDARD LIMITED WARRANTY INCLUDES:  
1 YEAR PARTS; 90 DAYS LABOR
- \* DISPLAY CASE(S) TO BE LABORATORY CERTIFIED AS DESCRIBED

O  
P  
T  
I  
O  
N  
A  
L

\* CASTERS

\* SIDE & FRONT PANELS PAINTED IN A GLOSSY FINISH (CASE SHIPS WITH MATTE WHITE FINISH)



### Ventura XP II Tecnica Hot Case Technical Specifications

*Wet or Dry Hot*

Model no.	Factory Code	Case Height	*Case Length	Case Depth	Crated Weight	* Line Voltage	Breaker Size
TH44	CS 2M	53.35"	44.50"	47.75"	624	220/1/60	20amps
TH65	CS 3M	53.35"	65.00"	47.75"	624	220/1/60	20amps
TBM65	CBM 3M	53.35"	65.00"	47.75"	734	220/1/60	30amps

\* Case length is the same with either decorative or flat end panels

\* Available in 3 Phase

\* Type of end panel to be specified at time of order

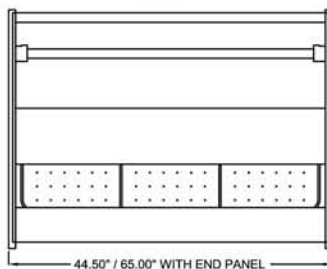

PLAN & REAR VIEW

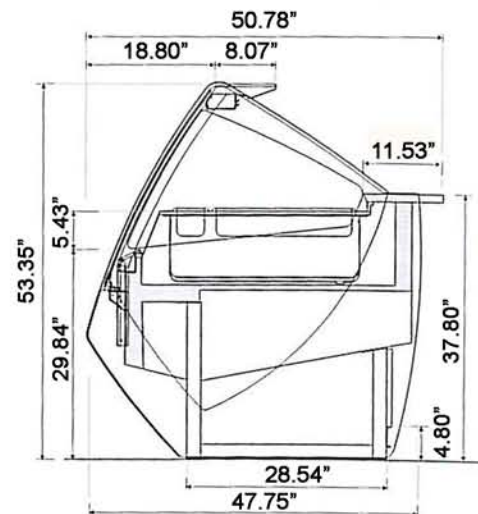

SIDE VIEW

#### LISTINGS:

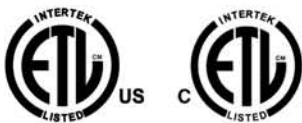

#### ELECTRICAL CONNECTION

Display cases are shipped with applicable junction box for hardwired installation  
 Options exist for several NEMA configurations  
 Plug and/or receptacle configurations are at the discretion of the electrical installer

#### NOTE:

Required ambient conditions: 75°F; 55% RH  
 Drawing and Specifications are subject to change without notice

CLABO North America, LLC  
 33300 Central Avenue  
 Union City, CA 94587 USA  
 PH 800.672.2784  
 FAX 510.441.0401  
<http://www.otl-usa.com>