



**OSCARTIELLE**

# BANCO POZZETTI

**GB** TECHNICAL HANDBOOK

**ENGLISH**



# Indice

---

<b>1</b>	<b>STANDARDS AND REGULATIONS.....</b>	<b>3</b>
1.1	Warranty: .....	3
1.2	Environmental notes: .....	3
1.3	Identification: .....	4
<b>2</b>	<b>RECEIPT AND INSTALLATION .....</b>	<b>4</b>
2.1	Lifting and Movement: .....	5
2.2	Positioning: .....	5
2.3	Environmental Specifications: .....	6
2.4	Hydraulic connection .....	6
2.5	Glycol filling:.....	6
2.6	Electrical connections: .....	6
<b>3</b>	<b>FUNCTIONING.....</b>	<b>7</b>
3.1	Start-up:.....	7
3.2	Command Console:.....	8
3.3	Keyboard.....	8
3.4	The meaning of the leds .....	8
3.5	How to visualise and change the set point .....	8
3.6	How to change parameter(s) value(s) .....	9
3.7	Local Alarms.....	9
3.8	Stopping the Machine: .....	9
<b>4</b>	<b>MAINTENANCE AND CLEANING.....</b>	<b>10</b>
4.1	Preliminary operations: .....	10
4.2	Cleaning the condenser: .....	10
4.3	General Clenaing: .....	10
<b>5</b>	<b>PRACTICAL TROUBLESHOOTING GUIDE .....</b>	<b>11</b>
<b>6</b>	<b>ELECTRICAL DIAGRAMS.....</b>	<b>12</b>
<b>7</b>	<b>REFRIGERATING SYSTEM DIAGRAMS.....</b>	<b>13</b>

*Rev.1.0 – 06/03/2009*

---

## **DEAR CUSTOMER**

This Manual or Technical Guide is a part of the Product and its target is to show use and maintenance of the cabinet. The operators have the responsibility of reading it and following the instruction reported on it. No other use of the display cabinet is allowed other than indicated in this manual.

This manual must be kept in good conditions and follow the cabinet during its entire operative life until dismissing, in order to have all the information needed for maintenance of the qualitative and safety standards.

The Firm will not assume any responsibility for damage to people, animals or things, caused by failure to observe the indications reported on the present Manual or by uses of the equipment for any purposes other than the ones for which it has been designed and sold.

For operator's safety, all equipment devices must be kept in constant efficiency.

## **1 STANDARDS AND REGULATIONS**

### **1.1 Warranty:**

The equipment is covered by warranty for 12 months running from delivery date from producer to final user, intended to be as first purchaser customer.

The validity of the warranty is certified by the purchase receipt and the label attached to equipment and reporting the cabinet serial number.

This documentation must be kept by customer and must be stated or shown if requests for interventions are made whilst under guarantee. If failure in showing these documentations or presentation of altered or illegible documentation occur, the warranty will not cover the goods any more.

The warranty does not cover any malfunctioning caused by transport by third parties, by incorrect installation and maintenance, by negligence or carelessness of use and tampering by third parties, by modifications made without previous authorization by equipment producer.

To obtain a technical intervention under guarantee, a written request must be sent to the Sales Direction or to the nearest dealer.

**Clabo Group** at their own discretion will decide whether to repair or replace the component or the entire appliance.

**Clabo Group** rule out any further responsibility also regarding direct and/or indirect damage. If the display cabinet is replaced the warranty period is not renewed or prolonged.

La **Clabo Group** a proprio insindacabile giudizio, deciderà se riparare o sostituire i componenti o l'intera apparecchiatura.

### **1.2 Environmental notes:**

#### **- Packaging**

Do not throw away the packaging but separate the different types of material (cardboard, wood, steel, polyester etc.) and dispose of them in compliance with the regulations in force in the country where the display cabinet is to be used.

#### **- Display cabinet out of service**

At the end of the display cabinet's life span:

- Remove the refrigerant from the display cabinet refrigerant circuit.
- Empty all oil and remove all rubber parts (e.g. O-ring, gaskets)
- The display cabinet must be sent for destruction.



IMPORTANT INFORMATION FOR USERS ACCORDING TO ART.13 LEGISLATIVE DECREE JULY 25, NO. 151 “ACCOMPLISHMENT OF DIRECTIVES 2002/98/CE, 2002/90/CE AND 2003/108/CE, CONCERNING THE REDUCTION OF THE USE OF DANGEROUS SUBSTANCES IN ELECTRIC AND ELECTRONIC EQUIPMENT, AS WELL AS THE WASTE DISPOSAL”.

The sign of the crossed bin on the equipment or on its packing indicates that the product must be gathered separate from other waste at the end of its life. The equipment waste disposal must be accomplished using the RAEE waste disposal centres specifically authorized. Users can contact their jobber/distributor/producer for information. The correct separate collection and subsequent recycling, treatment and the environment-friendly disposal of the equipment helps to prevent possible negative effects on the environment as well as health problems and promotes the re-employment and/or recycling of the equipment components. The product disposal without respecting the law implies the enforcement of administrative sanctions provided for by the rule in force.

### 1.3 Identification:

The SERIAL NUMBER on the plate positioned on the back (operator side) of the display cabinet (fig.1) must be given when contacting the manufacturer or customer services.



**ATTENTION:** Maintenance of the good conditions and legibility of the label applied to the cabinet is recommended. Don't tamper with the label.

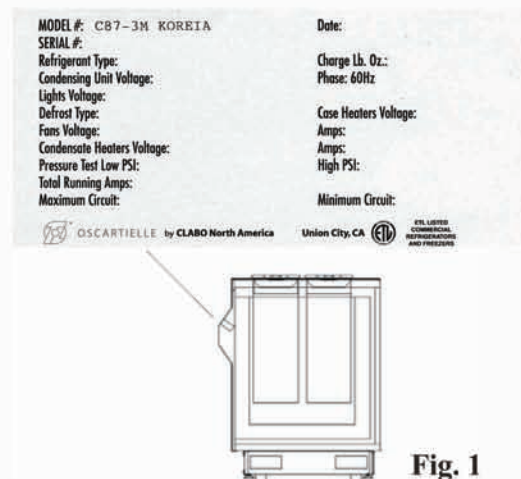

Fig. 1

## 2 RECEIPT AND INSTALLATION



**ATTENTION:** Before acceptance of the equipment, control the following:

- the package must be intact and the products haven't to be damaged during transport.
- the shipped goods correspond to the order specifications
- the presence and integrity of accessories
- possible damages occurred on products must be reported on the transport document for the compensation by the transport agency



**ATTENTION:** This product must be installed by qualified personnel. During installation the operators involved must wear Individual Protection Devices



**ATTENTION:** The installation of Remote Condensing Units (where available), must be performed by qualified personnel, following the instruction reported on manual delivered with the condensing unit itself and supplied by the factory.

## 2.1 Lifting and Movement:

The product is to be lifted by a transport vehicle using transport pallets or a fork lifted, in the following manner:

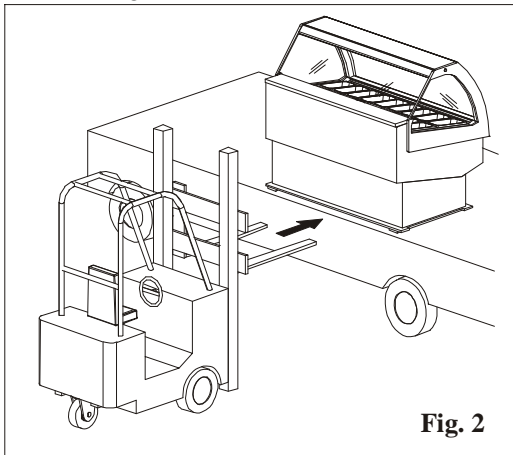

- Position the forks at the level of the vehicle (e.g. lorry).
- Move forward with the transport pallet so as to insert the forks under the cabinet.
- Ensure that the cabinet is perfectly balanced on the forks before lifting it (fig.2).
- Position the cabinet on the ground and remove the package.



**ATTENTION:** During the package wasting, using devices such as cutter could cause injuries to people or damages to product.

In addition, avoid to smear against the product with metallic parts such as watches, buckles, chains, rings and so on that could produce scratches.

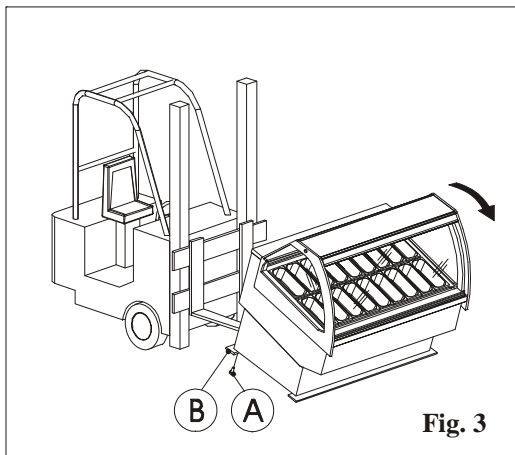

- Lift the cabinet using the pallets as shown in figure 3.
- Unscrew the screws that anchor the lists to the base (fig.3 pos. A) and remove the base (fig.3 pos. B).

Proceed in the same way to remove the other base.

The cabinet must be moved manually when on the ground.



**ATTENTION: TURNOVER OR SLIP DANGER**

Don't lift the cabinet more than 10 cm above the ground.

## 2.2 Positioning:

Please carry out the following operations to ensure correct positioning:

- Position the display cabinet leaving enough space for use and maintenance in safe conditions as envisioned by the UNIEN 292/2 Standard point 6.2.1 and in paragraph 2.6
- Check that there is a suitable earth plant present envisioned by European Standards.
- Once positioned in the desired area, make the display cabinet level using the adjustable feet (fig. 4).



**ATTENTION:** Before positioning the cabinet, assure that the floor is suitable for supporting its weight.

---

## 2.3 Environmental Specifications:

When positioning the display cabinet take into consideration that its operability is guaranteed in the following environmental conditions: temperature  $<30^{\circ}\text{C}$  and relative humidity  $<55\%$ .

It must also be checked that:

- there is sufficient circulation of air around the display cabinet but not strong currents;
- the display cabinet is not near any hot air sources;
- the display cabinet is not exposed to direct sunlight;
- the cooling air grills of the condenser are not blocked (fig. 5 pos. A);
- air conditioning or heating in the room are not directed onto the display cabinet.

The above-mentioned indications must be respected to prevent malfunctioning, which will not be covered by the warranty.

## 2.4 Hydraulic connection

For the display cabinets with water-cooled condenser the inlet and outlet pipes must be connected to the mains water system. The inlet pipe can be recognised as it is covered by heat insulation.

**ATTENTION!** Before using the display cabinet make sure taps are open and that water flows regularly (fig. 7).

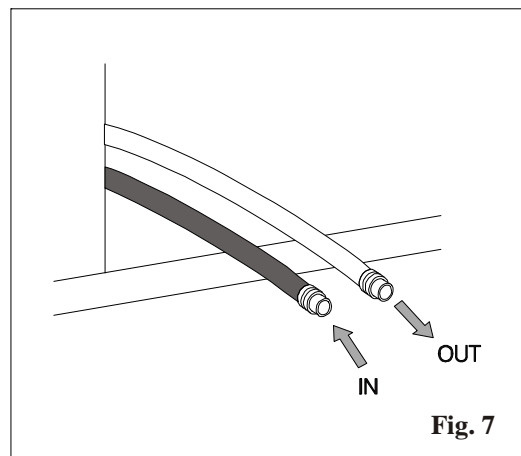

**ATTENTION:** Before switching the cabinet on, be sure that the manual taps in the water line are open and the water flows regularly. Then calibrate the presso-static water valve in function of the water external net pressure and temperature.



**ATTENTION:** Use of not-decalcified water could case irreparable damages to the system.

Use exclusively filtered and decalcified water.

## 2.5 Glycol filling:

Fill the counter basin with a 60% Glycole mixture (Water 40%, Glycol 60%).

## 2.6 Electrical connections:

Before installation, check that a suitable earth plant is present as envisioned by the regulations in force in the country of sale. Check that the mains voltage is compatible with the features stated on the plate positioned on the operator side of the display cabinet (see fig. 1 page 3). Also check that the line upstream from the display cabinet is appropriately dimensioned to support the load of the display cabinet itself.



**ATTENTION:** Voltage fluctuation above 10% of the nominal voltage stated on the plate can cause permanent damage to the compressor and other electro-mechanical equipment. In this case they are not covered by the warranty.

Respect national regulations for electrical installations.  
 Position the master switch in the OFF position.  
 The display cabinet is supplied with a 5-wire cable;  
 Yellow-green = Earth  
 Blue = Neutral  
 Brown = Phase 1  
 Grey = Phase 2  
 Black = Phase 3



**ATTENTION:** Never cut or remove the yellow-green cable mentioned above.

The five power supply wires must be connected to the back-bone network, which has a safe efficient earth system, in compliance with national and local regulations (where present) regarding electrical installations and suitable for the electric absorption of the display cabinet, refer to chapter 6 – Total Absorbed Power.



**ATTENTION:** The electrical connection to the mains must be made using the five wires supplied. Moreover, the central plant to which the display cabinet is connected must have a switch with contact opening of at least 3 mm protected by fuses.



**ATTENTION:** Apply a suitable method of fixing to the power supply cable on the connection box, making reference to the table shown below.

CORRENTE NOMINALE DELL'APPARECCHIO [A]	SEZIONE NOMINALE [mm <sup>2</sup> ]	
	CAVI FLESSIBILI [mm <sup>2</sup> ]	CAVI PER POSA A TERRA [mm <sup>2</sup> ]
3	0,5 ÷ 0,75	1 ÷ 2,5
3 ÷ 6	0,75 ÷ 1	1 ÷ 2,5
6 ÷ 10	1 ÷ 1,5	1 ÷ 2,5
10 ÷ 16	1,5 ÷ 2,5	1,5 ÷ 4
16 ÷ 25	2,5 ÷ 4	2,5 ÷ 6
25 ÷ 32	4 ÷ 6	4 ÷ 10
32 ÷ 40	6 ÷ 10	6 ÷ 16
40 ÷ 63	10 ÷ 16	10 ÷ 25

### 3 FUNCTIONING

#### 3.1 Start-up:

- 1) Activate the mains master switch.
- 2) Activate the display cabinet master switch, which is found on the rear protection panel. To introduce the electric power supply to the display cabinet, place the master switch at position "1" (fig. 8 pos. A).

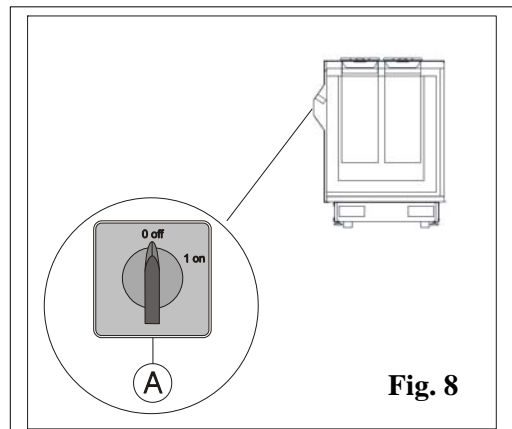

**Fig. 8**

---

### 3.2 Command Console:

The refrigerating plant of the display cabinet is controlled by means of an electronic console. The electronic console consists of:

- 1) Keyboard
- 2) Control board

### 3.3 Keyboard



- SET:** To visualise or change the set point. When programming this button is used to select a parameter or to confirm a value.
- ▲ (UP):** This button is used during programming for going through the parameter codes or for increasing their value.
- ▼ (DOWN):** This button is used during programming for going through the parameter codes or decreasing their value.
- ▲ + ▼** Pressed together they lock / unlock the keyboard
- SET + ▼** Pressed together for more than 3 seconds, enter the programming parameters
- SET + ▲** Pressed together one time exit from programming parameters.

### 3.4 The meaning of the leds

There are a series of luminous points on the display, the meaning of which you will find in the table below:

LED	MODE	Function
❄	ON	Compressor on
❄	FLASHING	Programming phase (flashing with LED ❄)
❄	ON	Defrosting active
❄	FLASHING	Dripping time underway
🔊	ON	ALARM SIGNAL - In the "Pr2" programme it indicates that the parameter is also present in "Pr1"

### 3.5 How to visualise and change the set point

- 1) Press the SET key and release it to see the set point: you will visualise the set point immediately.
- 2) To change the set point press the SET key and keep it pressed for 3 seconds: the led will flash ❄ ;
- 3) To change the value activate ▼ and ▲ .

To memorise the new set point, press the SET key or wait 15 seconds to exit the programming feature.



**ATTENTION:** the value displayed (setpoint value) is referring to the temperature of the anti-freezing liquid contained in the counter.

### 3.6 How to change parameter(s) value(s)

- 1) Access the programming mode, pressing SET + ▼ together for more than 3-4 seconds.
- 2) Select the parameter you need with ▼ e ▲
- 3) Press SET button to visualize the value of the parameter
- 4) Modify the value with ▼ e ▲ keys
- 5) Press SET button to memorize the new value.
- 6) Exit: press SET+ ▲, together when one parameter is visualized on the display, or wait for 15s without press any key

### 3.7 Local Alarms

MESSAGE	CAUSE	STATE OF OUTPUTS
“ P1 ”	Thermostat probe failure	Output according to “ Con “ and “ COF “ parameters
“ HA “	High temperature alarm	Unchanged
“ LA “	Low temperature alarm	Unchanged
“ EA ”	External Alarm	Unchanged
“ CA ”	External Alarm (i1F=bal)	Outputs off
“ dA ”	Open Door	Compressor regulated by “Odc” parameter

### 3.8 Stopping the Machine:

To stop the plant act on switch (A), which is found behind the rear protection panel. Position the master switch at “0” (fig. 8 pos. A) disconnecting the display cabinet power supply.

---

## 4 MAINTENANCE AND CLEANING



**ATTENTION:** All maintenance operations must be performed by expert qualified personnel.

Before performing any maintenance operation be sure that the cabinet is disconnected from electrical supply.

Wait until hot parts have cooled down and reached ambient temperature to avoid burning risk.

Wear suitable gloves during maintenance and cleaning operations to avoid contact with metallic parts which could cause injuries.

### 4.1 Preliminary operations:

Before carrying out any maintenance or cleaning the electric power supply must be disconnected by deactivating the plant master switch regarding the room where the display cabinet is positioned.

### 4.2 Cleaning the condenser:

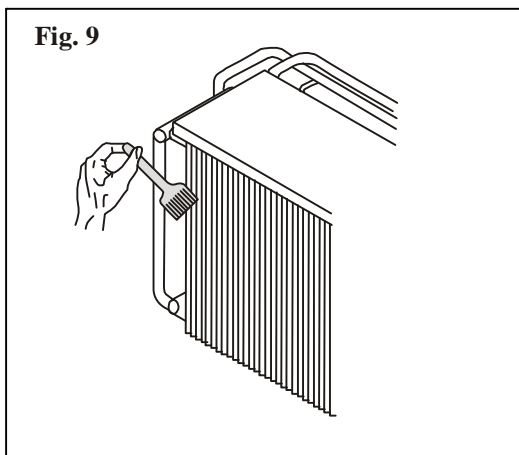

The deposit of dust and dirt in general on the condenser fins (air) reduces the efficiency of the plant until functioning is prevented and causing damage to the compressor. It is therefore absolutely necessary to periodically clean the condenser (every 20-30 days) as indicated below:

- Disconnect the electric power supply;
- Remove the rear metal grid;
- Remove the dust and dirt present on the condenser fins using a brush or suction device (fig. 9)
- Do not use stiff or metal objects to clean the condenser as they could damage it.



**ATTENTION:** During condenser cleaning operations don't use rigid or metallic objects that could damage it.

### 4.3 General Clenaing:

- **Steel surfaces:** Clean using a sponge or damp cloth, using water and/or neutral detergents, rinse and dry using a soft cloth.
- **Wooden surfaces:** Clean using a sponge or damp cloth, using water and/or neutral detergents, rinse and dry using a soft cloth.
- **Glass surfaces:** Clean using a sponge or damp cloth, using water and/or neutral detergents, rinse and dry using a soft cloth.
- **Plastic surfaces:** Clean with a sponge or a damp cloth, using water or neutral detergents. Rinse and dry using a soft cloth.
- **Chromium-plate surfaces:** Clean with a sponge or a damp cloth, using water or neutral detergents. Rinse and dry using a soft cloth.



**ATTENTION:** Use of abrasive, corrosive products, solvents, acids that could cause irreparable damages on surface and start corrosion must be avoided.  
Don't pour flammable products on hot parts such as lamps, LEDs, ballasts and so on.  
Don't pour water on electric components such as fan motors, lights and so on..



**ATTENTION:** During cleaning operations of movable glasses, be careful in opening and closing the glass, accompanying it until its final position. Avoid to lean on the open glass during cleaning phases.

## 5 PRACTICAL TROUBLESHOOTING GUIDE

### 1) Temperature of the display area not low enough (i.e. ice cream too soft)

<b>PROBABILE CAUSA</b>	<b>PROBABILE RIMEDIO</b>
Condenser blocked by dust or other.	Clean the condenser as indicated in point 4.2 Remove everything that obstructs regular air flow to the condenser.
The display cabinet is exposed to air currents or direct sunlight	The display cabinet does not function in these conditions; remove the display cabinet from the air currents and/or direct sunlight
Thermostat does not function correctly. With refrigerant system functioning perfectly the thermostat maintains a higher temperature than that set.	Call the after-sales service.
No water.	Check that there is flow of water; if so, call a technician due to possible breakage of the water valves or pressure switch or other causes.

### 3) The compressor never stops or works for long periods of time.

<b>PROBABLE CAUSE</b>	<b>PROBABLE SOLUTION</b>
The room temperature is very high (e.g.: above +32°C).	If the room temperature cannot be lowered (e.g. with air conditioner) the compressor must work almost continuously.
Air condenser blocked.	Clean the condenser as indicated in point 4.2
The thermostat is fixed at a room temperature that is too low.	Adjust the thermostat to a higher temperature, as indicated in point 3.5

### 4) The display cabinet does not work

<b>PROBABLE CAUSE</b>	<b>PROBABLE SOLUTION</b>
The plug is not inserted into the socket.	Insert the plug (see point 2.6)
Any automatic switch tripped.	Re-insert the automatic switch.
Display cabinet master switch open.	Close the display cabinet master switch (see point 3.1)

## 6 ELECTRICAL DIAGRAMS

The following electrical diagrams will have to be used by qualified personnel on the basis of the current regulations in vigour in the country of sale.

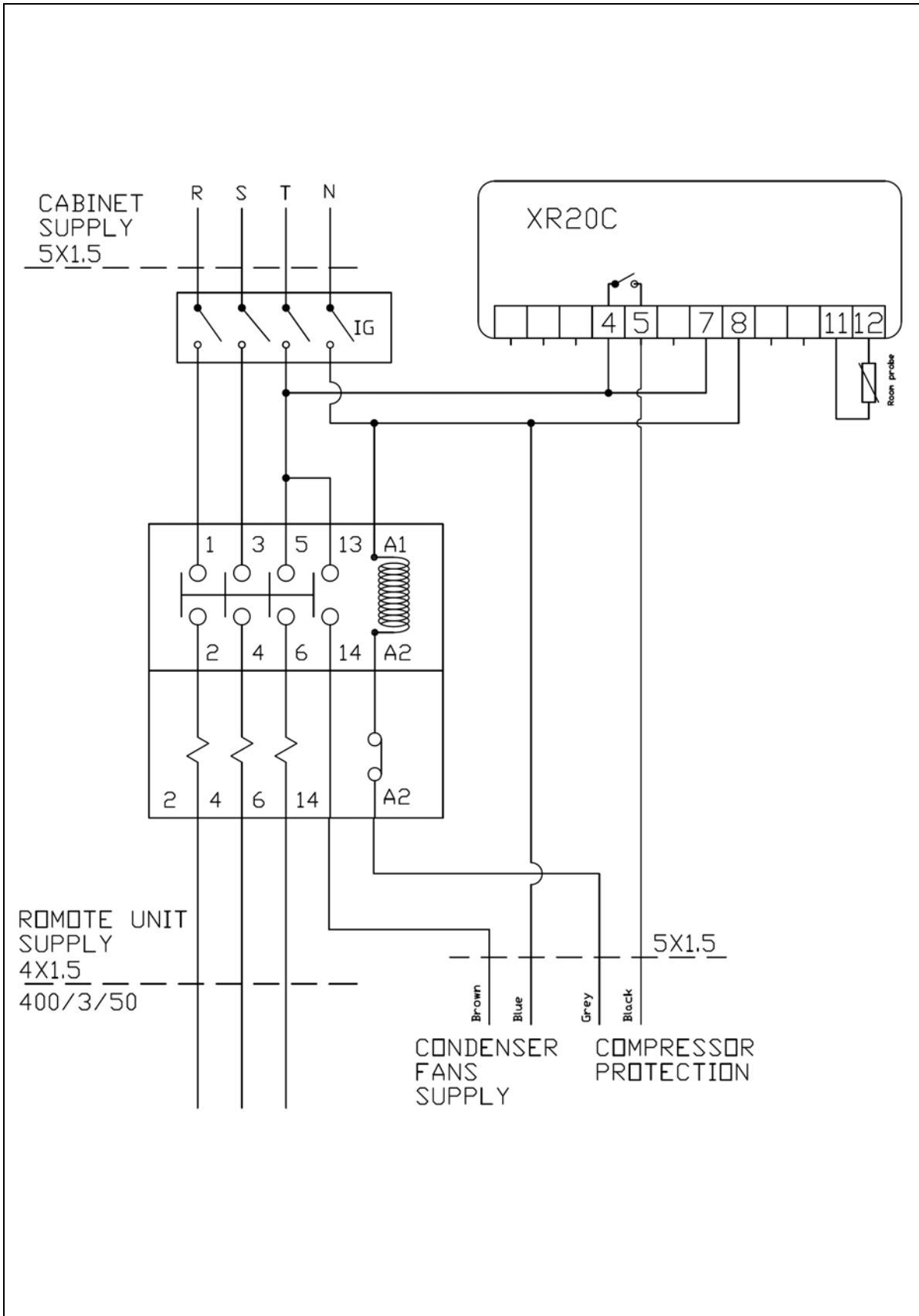

## 7 REFRIGERATING SYSTEM DIAGRAMS

1	Condensatore
2	Ventilatore condensatore
3	Ricevitore di liquido
4	Rubinetto
5	Filtro umidità
6	Valvola termostatica
7	Evaporatore
9	Compressore

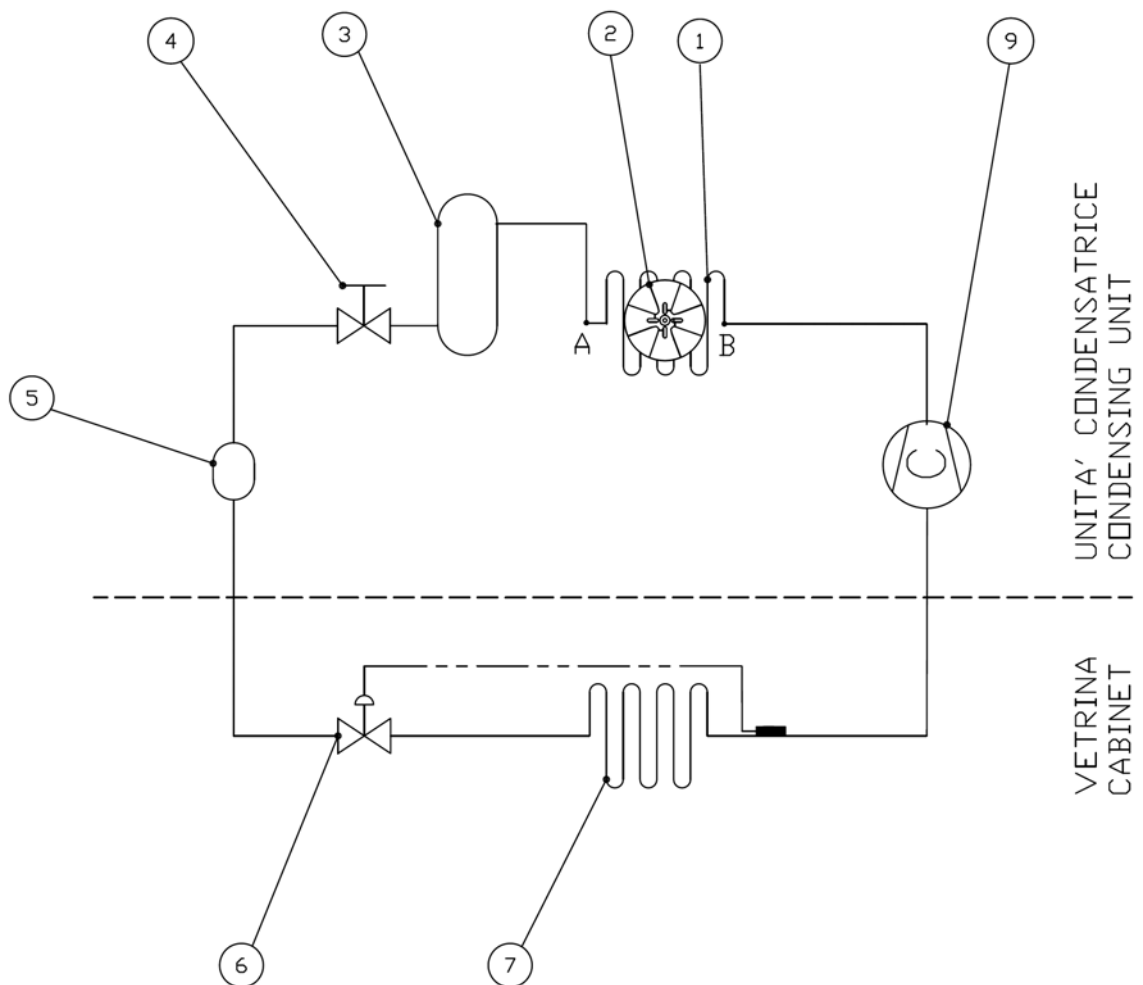

1	Condenser
2	Condenser fan
3	Liquid tank
4	Refrigerant ball valve
5	Filter
6	Thermostatic valve
7	Evaporator
9	Compressor



3330 Central Avenue | Union City, CA 94587  
Tel: 1.800.672.2784 | 510.441.0441 | Fax: 510.441.0401  
[www.clabona.com](http://www.clabona.com) | [www.otl-usa.com](http://www.otl-usa.com) | E-mail: [sales@clabona.com](mailto:sales@clabona.com)



60035 JESI (An) Italy - ZIPA - Viale dell'Industria  
Tel. +39 0731 61531 - Fax +39 0731 6153413  
[www.clabogroup.com](http://www.clabogroup.com) - E-mail: [info@clabogroup.com](mailto:info@clabogroup.com)