



# ITALIANA

## ICE CREAM CABINET

# TECHNICAL HANDBOOK

## CONTENTS

1	TECHNICAL NOTES .....	3
1.1	Description of the cabinet.....	3
1.2	ICE CREAM models dimensions.....	4
1.3	Unpacking the cabinet .....	4
2	INSTALLATION.....	5
2.1	Transportation .....	5
2.2	Handling and Lifting off of the Pallet .....	5
2.3	Positioning the cabinet .....	5
2.4	Environmental Conditions.....	6
2.5	Service of condensing units and under frame components .....	6
3	FUNCTIONS .....	7
3.1	Start-up .....	7
3.2	Command Console .....	7
3.3	Control Panel WX20LS.....	7
3.4	The meaning of the leds .....	8
3.5	How to see the min temperature.....	8
3.6	How to see the maximum temperature.....	8
3.7	How to reset the Max and min temperature recorded .....	8
3.8	How too see and modify the set-point.....	9
3.9	To start a manual defrosting .....	9
3.10	The ON/OFF function .....	9
3.11	Local alarms .....	9
3.12	Automatic defrosting.....	9
3.13	Stopping the Machine:.....	9
4	ROUTINE MAINTENANCE .....	10
4.1	Preliminary .....	10
4.2	Condenser cleaning .....	10
4.3	Cleaning the interior storage compartment .....	10
4.4	External cleaning of the cabinet .....	10
4.5	Weekly defrosting .....	10
5	PRACTICAL TROUBLESHOOTING GUIDE .....	11
5.1	Electrical Board.....	13
5.2	Thermodynamic Board.....	15

Rev. 10-10-08

## 1 TECHNICAL NOTES

### 1.1 Description of the cabinet

The cabinet is essentially made up of four sections:

- 1) Glass Structure
- 2) Display Area
- 3) Frame
- 4) Cooling system

1) The glass structure is made up of two side panels of insulated tempered glass that have conductive heated strips to minimize condensation on the glass surface. The front glass is enclosed in a metal frame which is hinged at the bottom for ease of cleaning. The front glass is also insulated and includes heating strips to minimize fog and condensation.

The top support frame includes the following components:

- Door tracks
- Product display light
- Work top

2) The display area is highly insulated with high density polyurethane so it has a low coefficient of conductivity. In the display area there are the evaporators and the ventilator fans which cool and dry the air and gently circulate it through the cabinet. In the interior is placed a bar which supports the rows of display pans. The pitch of the pans enhances the view of the display and allows for under storage of product depending on pan size used.

3) The frame structure is made of high quality, durable steel. In this structure all of the cabinets cooling, electrical and mechanical items are located for ease of service.

4) The cooling system is made up of:

- Condensing unit(s)
- Evaporator unit(s)

The condensing unit includes the compressor and the condenser. This assembly is mounted on tracks or rails which can be slid out to aid in the ease of servicing. The evaporators include the evaporator assembly with its own fan motors which keep the required temperature for the products placed in the display area of the cabinet.

NOTE: Directly below the rear work surface is the machine identification data plate. This data plate includes all of the machines pertinent information for servicing, model number, serial number and should be referenced when initiating a service call.

## 1.2 ICE CREAM models dimensions

TYPE	P [mm]	L [mm]	L' [mm]	H [mm]	WEIGHT(Kg)
<b>G 10</b>	950	1000	1072	1371	--
<b>G 16</b>	950	1500	1572	1371	--
<b>G 22</b>	950	2000	2072	1371	--

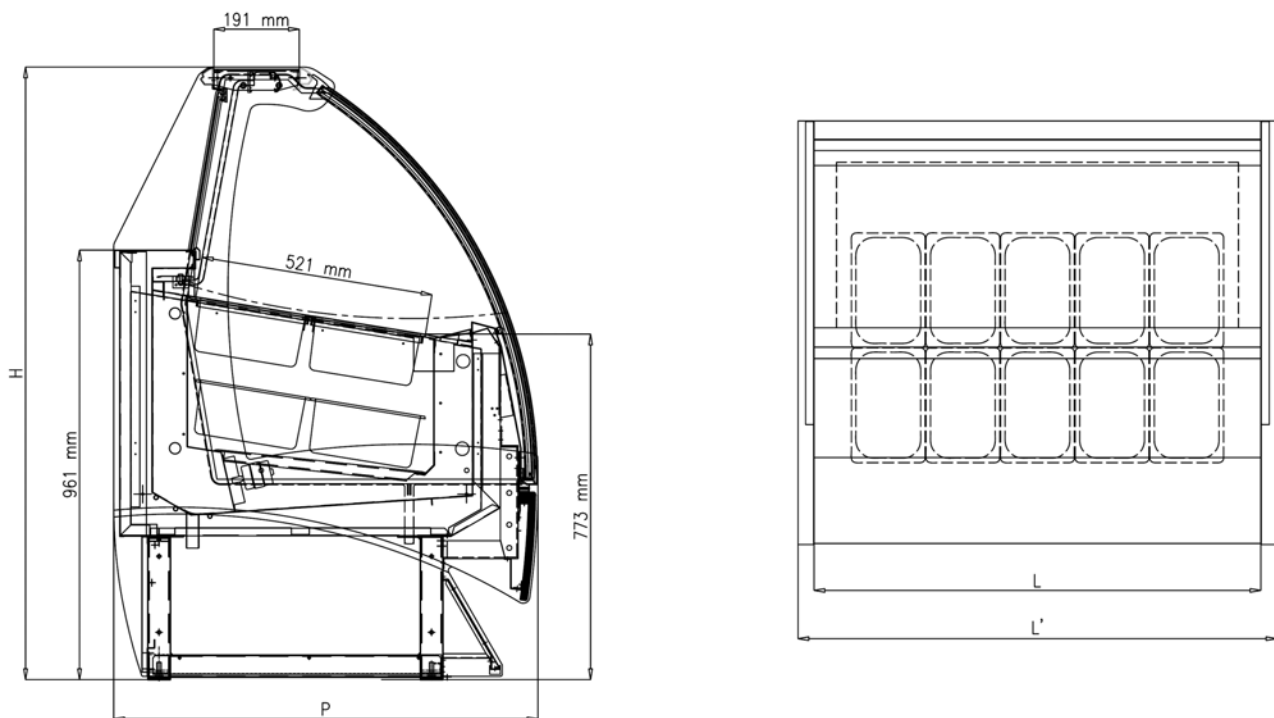

## 1.3 Unpacking the cabinet

### - Packaging

Before removing any of the protective packing materials from around the machine, carefully inspect for any damage. This **MUST** be noted on the freight bill if damage has occurred and a freight claim filed.

## 2 INSTALLATION

### 2.1 Transportation

Two wooden rails are bolted to the bottom side of the machine frame structure of the cabinet. These wooden rails are in turn fastened to the main shipping skid or pallet, which holds the cabinet firmly in place during transportation. To remove the machine from the pallet, you must first remove these screws.

### 2.2 Handling and Lifting off of the Pallet

The display cabinet is lifted from the transport pallet in the following manner.

- Put the forks beside the machine as shown below.
- Ensuring that the forks are completely under the entire display cabinet and centered from side to side on the cabinet (see fig.1 below). You are now ready to lift off of the pallet.
- After removing from the pallet, place the display cabinet on the floor.
- To remove the wooden rails from the bottom, *CAREFULLY* lift and tip the display cabinet using the fork lit as illustrated in figure # 2.
- Unscrew the bolts which hold the rails to the bottom frame structure (fig.2 pos.A) and remove the rails from the supporting structure (fig.2 pos.B).
- Remove the other supporting structure and continue in the same way.

The movement and placement of the display cabinet must now be done by hand once it has been placed on the floor. *NEVER* push or try to move the cabinet by pushing or pulling on any side of the glass structure.

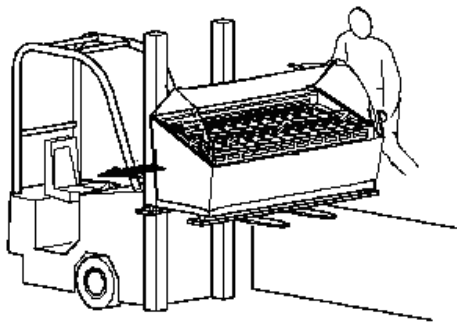

fig. 1

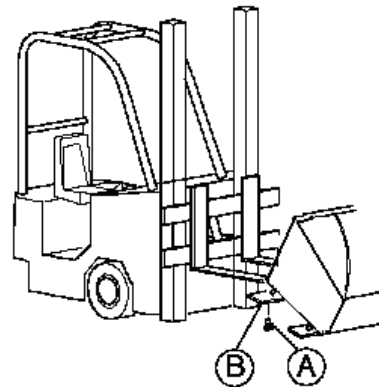

fig. 2

### 2.3 Positioning the cabinet

Before starting the installation, please ensure that the following clearances are maintained:

- A minimum space of 1500 mm customer side, and 700 mm operator side is maintained
- Check that there is an appropriate power supply is provided according to the local and or national standards.
- After the final position is located, seal base of the cabinet with silicone sealant to the floor along the bottom frame rail.
- Using a level, precisely level the cabinet front to back, side to side as shown.

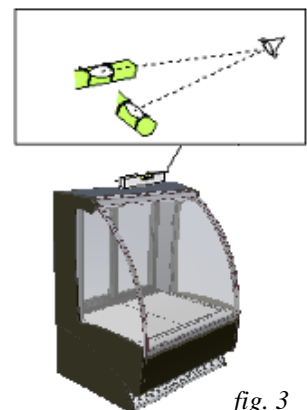

fig. 3

## 2.4 Environmental Conditions

When the cabinet has been positioned, please take note that its operation is affected by inside conditions. The temperature of  $< 25^{\circ}\text{C}$  ( $77^{\circ}\text{F}$ ) and with a relative humidity of  $< 55\%$  should be maintained to ensure proper cabinet operating conditions.

During the installation we must also check that:

- There is a sufficient air circulation and that there are no direct drafts onto the cabinet.
- The cabinet is not situated near any heat sources
- The cabinet is not exposed to direct sunlight at any time
- The grill for the air condenser is not obstructed, and air is allowed to flow freely
- Air conditioning or heating in the room are not directed near the cabinet.



IMPORTANT INFORMATION FOR USERS ACCORDING TO ART.13 LEGISLATIVE DECREE JULY 25, NO. 151 “ACCOMPLISHMENT OF DIRECTIVES 2002/98/CE, 2002/90/CE AND 2003/108/CE, CONCERNING THE REDUCTION OF THE USE OF DANGEROUS SUBSTANCES IN ELECTRIC AND ELECTRONIC EQUIPMENT, AS WELL AS THE WASTE DISPOSAL”.

The sign of the crossed bin on the equipment or on its packing indicates that the product must be gathered separate from other waste at the end of its life. The equipment waste disposal must be accomplished using the RAEE waste disposal centres specifically authorized. Users can contact their jobber/distributor/producer for information. The correct separate collection and subsequent recycling, treatment and the environment-friendly disposal of the equipment helps to prevent possible negative effects on the environment as well as health problems and promotes the re-employment and/or recycling of the equipment components. The product disposal without respecting the law implies the enforcement of administrative sanctions provided for by the rule in force.

It is essential to the proper operation of the case that all of the above items are strictly adhered to, all of which could adversely affect cabinet performance. It could also damage machine components, which will void the warranty on the machine and its components.

## 2.5 Service of condensing units and under frame components

In the event that service is required, it might be necessary to remove the condensing unit(s) from the cabinet. To do so, the rear panel must be first removed and adequate space provided to slide them out of the rear of the cabinet (see fig.4). It is therefore necessary to have adequate space behind the cabinet for this process to take place.

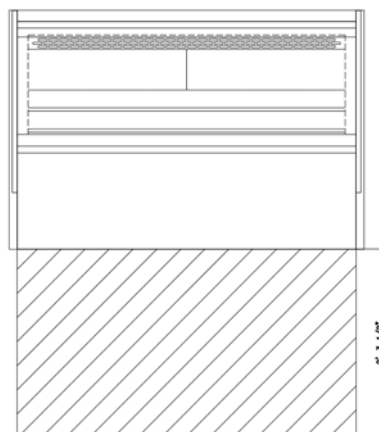

fig. 4

### 3 FUNCTIONS

#### 3.1 Start-up

- 1) Activate the mains master switch.
- 2) Activate the display cabinet master switch, which is found on the rear protection panel. To introduce the electric power supply to the display cabinet, place the master switch at position “1” (fig. 5 pos. A).

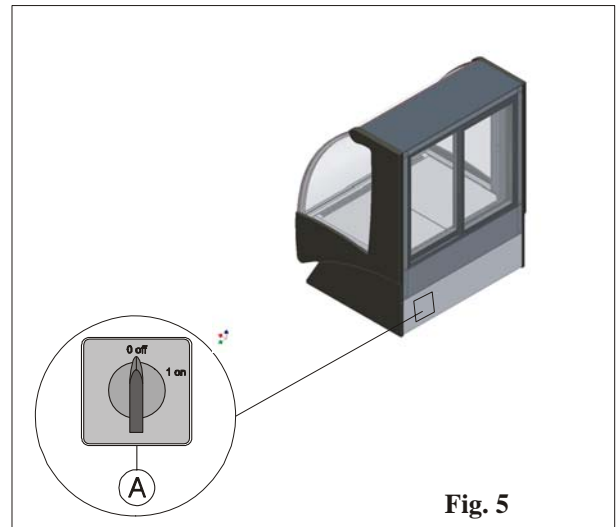

Fig. 5







#### 3.2 Command Console

The refrigerating plant of the display cabinet is controlled by means of an electronic console. The electronic console consists of:







- 1) Keyboard
- 2) Control board

#### 3.3 Control Panel









-  To see or modify the Set-point. In programming mode it select a parameter or confirm a value. If pressed for 3s during the visualization of the Max or min temperature it reset that.
-  To see the maximum reached temperature. In programming mode it scrolls the parameters codes or increases the value. If pressed for 3s it allows fast-cooling cycle.
-  To see the minimum reached temperature. In programming mode it scrolls the parameters codes or decreases the value.
-  Holding it down for 3s it starts the manual defrosting cycle.
-  It switches ON and OFF the cabinet's lights.
-  It switches ON and OFF the main control.

### Key combination



-  +  To lock and unlock the keyboard
-  +  To enter the programming code
-  +  To exit the programming code

### 3.4 The meaning of the leds



There are a series of luminous points on the display, the meaning of which you will find in the table below:

LED	MODE	FUNCTION
	ON	The compressor is running
	FLASHING	Programming phase (flashing with LED  )
	ON	The defrost is enabled
	ON	Fast freezing cycle is enabled
	ON	The light is ON
	ON	Alarm signal - in “Pr2” indicates that the parameter is also present in “Pr1”

### 3.5 How to see the min temperature

-  1. Press and release the  key.
2. The “Lo” message will be displayed followed by the minimum temperature recorded.
3. By pressing the  key or waiting for 5s the normal display will be restored.

### 3.6 How to see the maximum temperature

-  1. Press and release the  key
2. The “Hi” message will be displayed followed by the maximum temperature recorded.
3. By pressing the  key or waiting for 5s the normal display will be restored.



### 3.7 How to reset the Max and min temperature recorded

1. To reset the stored temperature, when Max or min temperature is displayed:
2. Press SET key until “rST” label starts blinking

**N.B.:** After the installation **RESET** the temperature stored

### 3.8 How too see and modify the set-point



1. Push and immediately release the SET key: the display will show the Set-point value.
2. The SET LED start blinking
3. To change the Set value push the  or  arrows within 10s.
4. To memorize the new Set-point value push the SET key again or wait for 10s

### 3.9 To start a manual defrosting



1. Push the DEF key for more than 2s and a manual defrost will start.

### 3.10 The ON/OFF function



By pushing the ON/OFF the instrument shows “OFF” for 5s and the “ON/OFF” LED is switched OFF.

During the OFF status, all the relays are switched off and the regulations are stopped.

N.B. During the OFF status the Light button is active

### 3.11 Local alarms

MESSAGE	CAUSE	OUTPUTS
“ P1 ”	Thermostat probe failure	Alarm output ON; compressor output according to parameters “Con” and “Cof”
“ HA “	Maximum temperature alarm	Outputs unchanged
“ LA “	Minimum temperature alarm	Outputs unchanged
“ EE ”	Data or memory failure	

### 3.12 Automatic defrosting

The display cabinet is complete with an automatic “hot gas” defrosting system that allows for rapid elimination of ice formations on the evaporator fins. The automatic defrosting process is set in the standard configuration every 8 hours.

### 3.13 Stopping the Machine:

To stop the plant act on switch (A), which is found behind the rear protection panel. Position the master switch at “0” (fig. 5 pos. A) disconnecting the display cabinet power supply.

## 4 ROUTINE MAINTENANCE

### 4.1 Preliminary

**WARNING! Before starting any maintenance or cleaning operation it is necessary to disconnect the power supply to the cabinet at the main power disconnect or breaker box.**

After turning off the power to the machine, you must then disconnect the main switch, which is located on the lower rear, left side of display cabinet. (see fig 5)

### 4.2 Condenser cleaning

The dust and dirt deposits, generally situated on the fins of the air condenser, reduces the efficiency of the system and could eventually prevent it from functioning. It may also cause compressor damage if not cleaned regularly, so it is absolutely necessary to clean the condenser periodically (every 30 days). To do so, proceed as follows:

- Disconnect the power supply
- Removing the rear panel
- Remove the dust and the dirt in the condenser fins using a brush or a vacuum cleaner with a soft brush attachment (see fig. 6)

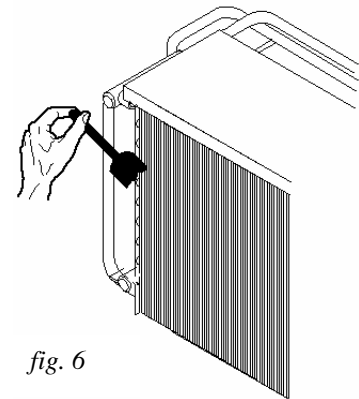

fig. 6

**WARNING! Do not use metal or rigid tools, as they could bend the cooling fins which could reduce efficiency or damage the condenser tubing.**

- Reinstall the rear panel
- Reconnect power to the machine

### 4.3 Cleaning the interior storage compartment

The interior of the cabinet needs to be cleaned periodically. Once a week is the recommended cleaning cycle for the inside display area. To clean, proceed as follows:

- Remove the product from the display cabinet
- Disconnect the power supply to the cabinet
- Allow the cabinet defrost for about 90 minutes or until the ice is totally melted.
- Clean the interior of the cabinet with a sponge or cloth and warm water without detergents.

**WARNING! Avoid the use of large quantities of water as it could overflow the condensation collecting pan inside the cabinet frame.**

### 4.4 External cleaning of the cabinet

The outside of the cabinet could be cleaned with warm water and mild detergent. When cleaning it is critical that you **NEVER** use steel wool, abrasives, glass paper or similar products. Never use aggressive chemical products such as acids, chlorines, ammonia, etc as it could damage or destroy the cabinet surfaces. Clean with a soft cloth or sponge.

**WARNING!** Absolutely avoid the use of pure alcohol.

### 4.5 Weekly defrosting

To ensure that the cabinet operates at maximum efficiency we suggest that you defrost the cabinet weekly and for a prolonged period (about 12 hours minimum). In order to do this, please disconnect the power supply to the cabinet. Allow the cabinet to stay idle for this prolonged period, which will ensure all ice has been defrosted and drained from the storage area.

## 5 PRACTICAL TROUBLESHOOTING GUIDE

### 1) Temperature of the display area not low enough (i.e. ice cream too soft)

PROBABLE CAUSE	PROBABLE SOLUTION
Evaporator blocked by ice.	Defrost as indicated: - transfer the product from the display cabinet to a freezer at $-20^{\circ}\text{C}$ . - disconnect the main switch for 10/12 hours in a way to defrost the evaporator (point 4.3).
Condenser blocked by dust or other.	Clean the condenser as indicated in point 4.2 Remove everything that obstructs regular air flow to the condenser.
The fans do not function and/or their blades are damaged.	Request after-sales service for replacement
The display cabinet is exposed to air currents or direct sunlight	The display cabinet does not function in these conditions; remove the display cabinet from the air currents and/or direct sunlight
Thermostat does not function correctly. With refrigerant system functioning perfectly the thermostat maintains a higher temperature than that set.	Call the after-sales service.
There is no regular chilled air flow (the “blade of air”) on the ice cream.	Check the air circuit (fan area, area below the evaporator) and remove any obstructions to the circulation of cold air.
No water.	Check that there is flow of water; if so, call a technician due to possible breakage of the water valves or pressure switch or other causes.

### 2) The defrosting water does not drain off properly (that is, the water obtained during the automatic or manual defrosting phases).

LIKELY CAUSE	LIKELY REMEDY
The defrosting water drainage tube that goes from the cold tub to the tub in which such water is channelled (for evaporation) is blocked.	Open up the drainage tube
The display cabinet is positioned on the ground in such a way that the drainage water is not directed towards the outlet hole.	Ensure that the display cabinet is level on the ground as outlined in point 2.2. It must be completely level.

### 3) The compressor never stops or it works for very long periods of time.

PROBABLE CAUSE	PROBABLE SOLUTION
The room temperature is very high (e.g.: above $+32^{\circ}\text{C}$ ).	If the room temperature cannot be lowered (e.g. with air conditioner) the compressor must work almost continuously.
Air condenser blocked.	Clean the condenser as indicated in point 4.2
The thermostat is fixed at a room temperature that is too low.	Adjust the thermostat to a higher temperature, as indicated in point 3.5
The fans are at a standstill.	Call the after-sales service to identify the cause and to replace them if necessary

**4) The display cabinet does not work**

<b>PROBABLE CAUSE</b>	<b>PROBABLE SOLUTION</b>
The plug is not inserted into the socket.	Insert the plug (see point 2.6)
Any automatic switch tripped.	Re-insert the automatic switch.
Display cabinet master switch open.	Close the display cabinet master switch (see point 3.1)

**5) The light does not work**

<b>PROBABLE CAUSE</b>	<b>PROBABLE SOLUTION</b>
Light switch not closed.	Close the light switch
The fluorescent bulb is not inserted correctly into the socket.	Insert the bulb correctly.
The bulb has burned out.	Replace the bulb
The “starter” is finished.	Replace the “starter”

### 5.1 Electrical Board

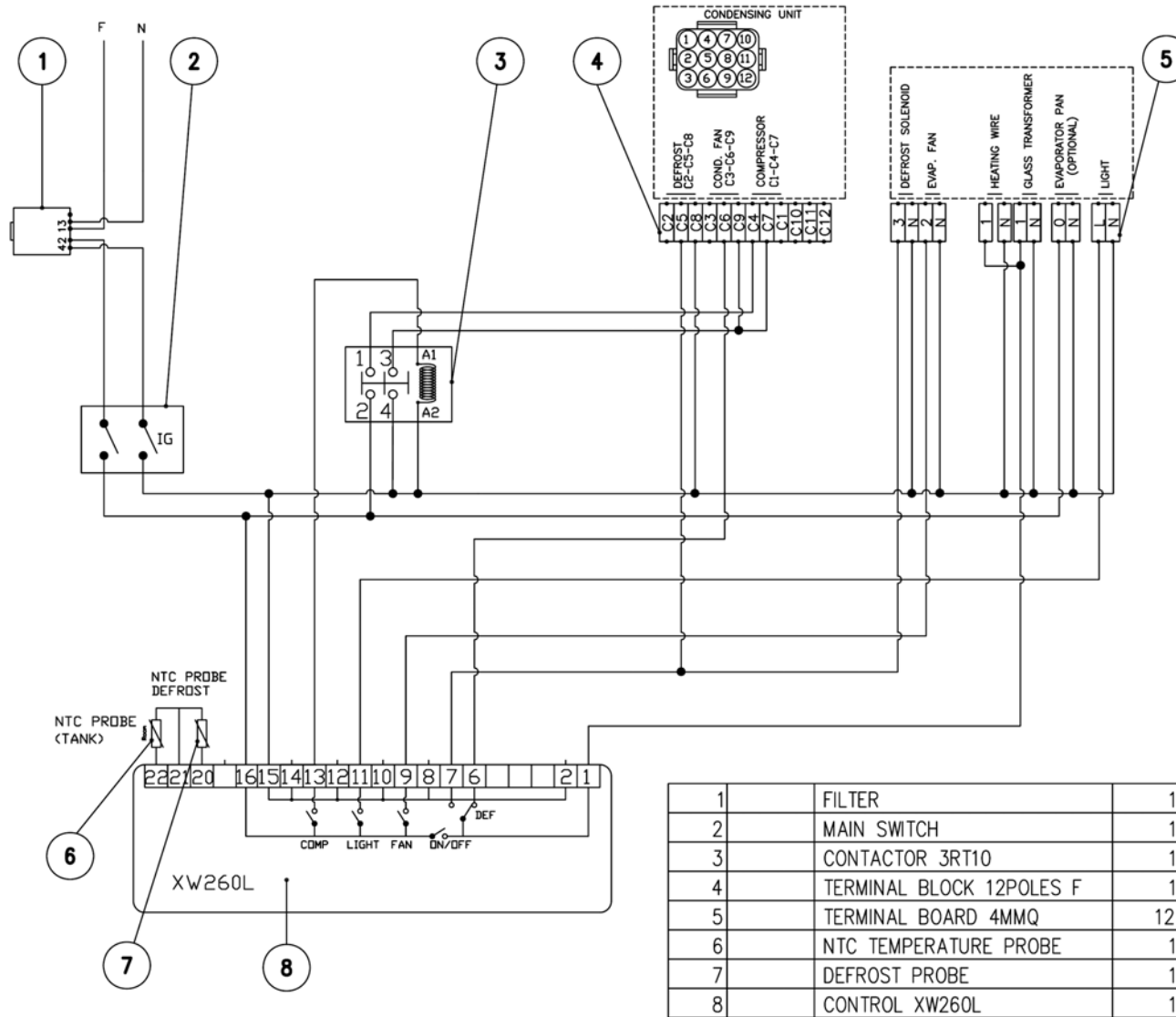

9	Compressor	1
10	Condenser fan	1
11	Solenoid EVR-6	2
12	Fan 52 220/50-60	2
13	Thermal protection	1
14	Terminal block 4 poles	1
15	Heating wire	2...3
16	Glass transformer 230	1
17	Heating DX side panel	1
18	Heating SX side panel	1
19	Lamp	2
20	Ballast	1

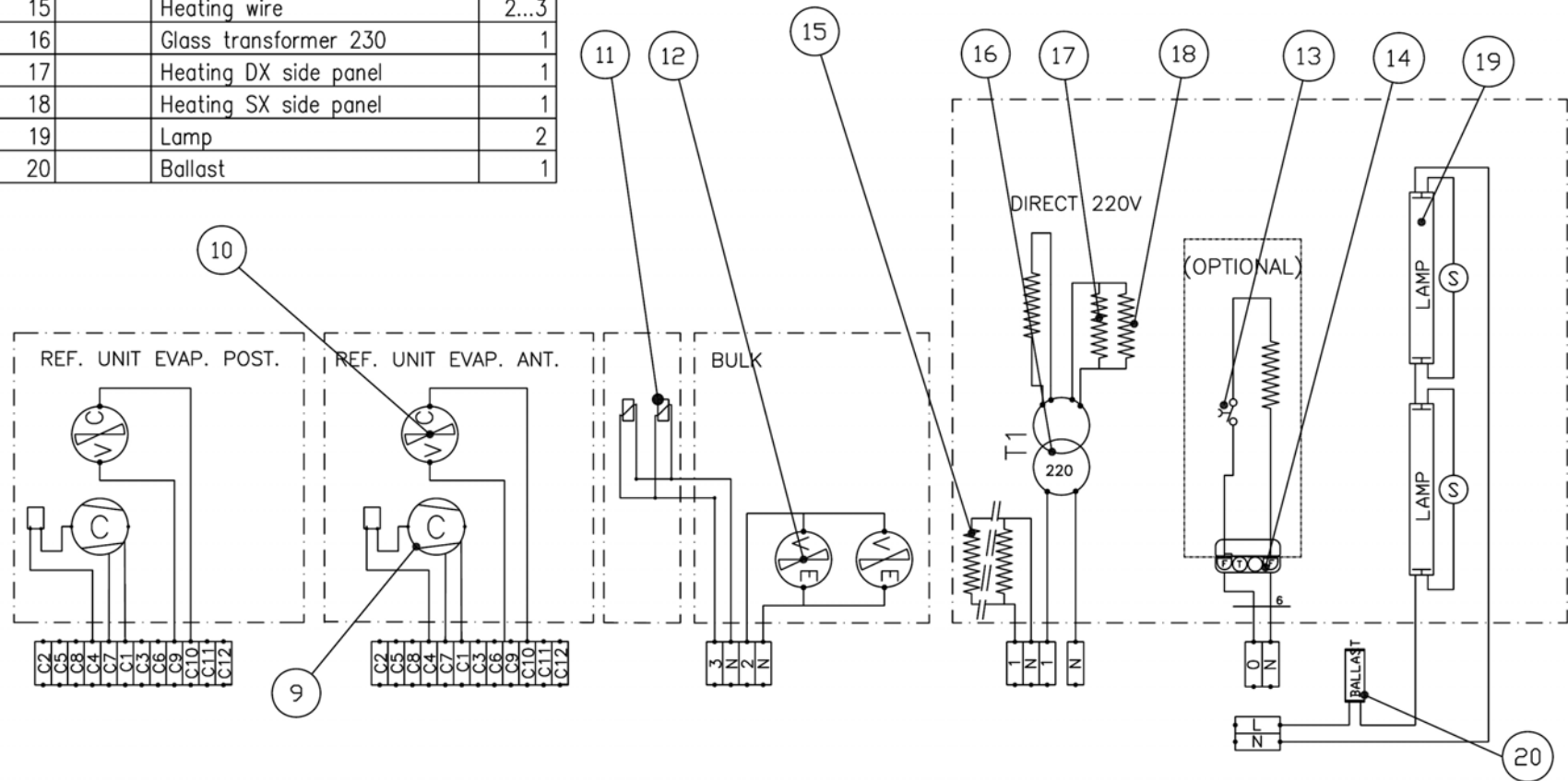

## 5.2 Thermodynamic Board

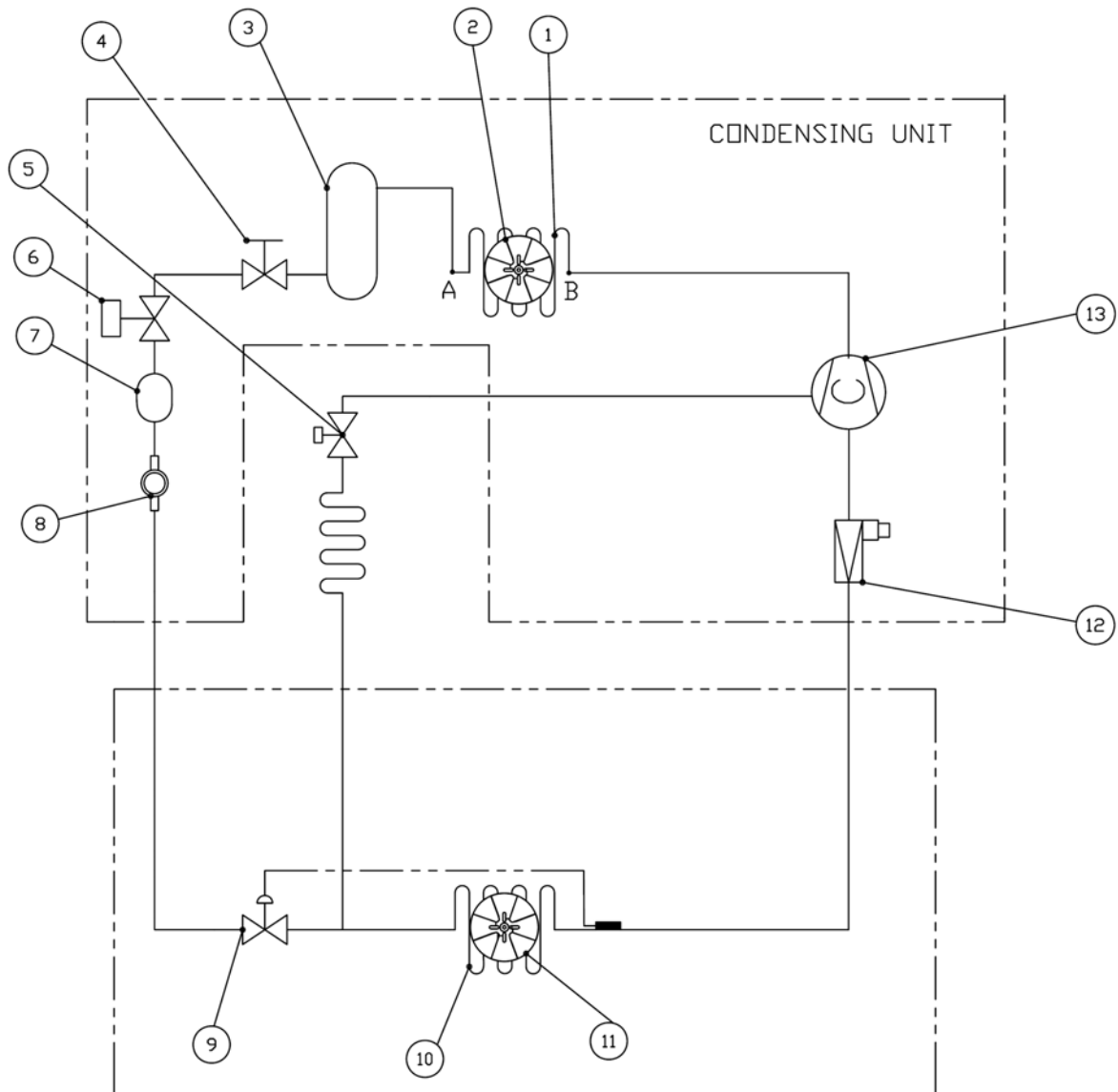

1	Condenser
2	Condenser fan
3	Liquid receiver
4	Refrigerant ball valve
5	Solenoid valve hot gas
6	Pressure control (only for water unit)
7	Filter
8	Spy glass (optional)
9	Thermostatic valve
10	Evaporator
11	Evaporator fan
12	Pressure regulating valves KVL
13	Compressor