



KT 24 Ice Cream Cabinet

Use and Maintenance Manual



- English -

INDEX

1.	Standards and Regulations	5
1.1	Warranty.....	5
1.2	Identification	5
1.3	Technical Assistance.....	6
2.	Data and Technical Characteristics	7
2.1	Main Characteristics	7
2.2	Tech Data	8
3.	Receipt and Installation.....	9
3.1	Lifting and Movement	9
3.2	Positioning	10
3.3	Environmental Conditions	11
3.4	Canalization	11
3.5	Plumbing Connections	12
3.6	Electrical Connections	12
3.7	Water Drainage	13
3.8	Remote Compressor(s) Installation.....	14
3.9	Raw Cabinet Covering.....	14
3.10	End of Service and Disposal	14
4.	Functioning.....	15
4.1	General Use Rules.....	15
4.2	Start Up	16
4.3	Control Board.....	16
4.4	Visualize Minimum Recorded Temperature.....	17
4.5	Visualize Maximum Recorded Temperature	17
4.6	Reset Minimum / Maximum Recorded Temperature	17
4.7	Setpoint visualization and Change.....	18
4.8	Manual Defrosting Cycle	18
4.9	Stand-By Function	18
4.10	Local Alarms.....	18

4.11	Reserve Control Panel.....	19
4.12	Reserve Setpoint Visualization and Change	20
4.13	Local Alarms.....	20
4.14	Cabinet with Independent Sector (“ <i>Fruttini</i> ”)	20
4.15	Optional Kit KVP – Ice Cream / Pastry Change.....	21
4.16	Stopping the Machine	21
5.	Cleaning and Maintenance.....	21
5.1	Ordinary Maintenance: Daily Cleaning	22
5.2	Ordinary Maintenance : Weekly Cleaning.....	22
5.3	Programmed Maintenance – Condenser Cleaning.....	23
5.4	Summary of scheduled Maintenance	24
6.	Practical Troubleshooting Guide.....	25
7.	Electrical Drawings (<i>standard version</i>).....	28
7.1	Electrical Diagram KT 24 G6-G9-G12-A30-C30 (<i>1 Semihermetic Compressor</i>)	28
7.2	Electrical Diagram KT 24 A45 (<i>1 Hermetic Compressor – hot gas system defrost</i>).....	29
7.3	Light Connections	30
7.4	Condensing Unit Connection Box (Internal or Remote Unit)	31
8.	Cooling Systems Diagrams.....	32
8.1	Cooling System w/ Cycle Inversion Defrost – G6-G9-G12-A30-C30.....	32
8.2	Cooling System w/ Hot Gas Defrost – A45.....	33
8.3	Optional Kit KVP – Pastry / Ice Cream passage	34

Dear Customer

. This Manual or Technical Guide is a part of the Product and its target is to show use and maintenance of the cabinet. The operators have the responsibility of reading it and following the instruction reported on it. No other use of the display cabinet is allowed other than indicated in this manual.

This manual must be kept in good conditions and follow the cabinet during its entire operative life until dismissing, in order to have all the information needed for maintenance of the qualitative and safety standards.

The Firm will not assume any responsibility for damage to people, animals or things, caused by failure to observe the indications reported on the present Manual or by uses of the equipment for any purposes other than the ones for which it has been designed and sold.

For operator's safety, all equipment devices must be kept in constant efficiency.

1. STANDARDS AND REGULATIONS

1.1 WARRANTY

Products are covered by guarantee for 14 months running from delivery date. The validity of the guarantee is certified by the purchase receipt and the label attached to equipment and reporting the serial number.

Such documentation will have to be stored by the customer and referred to or exhibited in case of interventions requests during the guarantee period. Loss of such documentations or any modification thereof which might render it illegible, will lead to guarantee immediate annulment.

Possible damage or malfunctioning caused due to transport by third parties, by incorrect installation and maintenance, by negligence or carelessness of use and tampering by third parties, by components wear, modifications made without previous Clabo Group authorization, will not be covered by guarantee

To obtain a technical intervention under guarantee, a written request will have to be sent to the Sales Management Division or to the nearest dealer. According to its own unquestionable judgement Clabo Group will decide whether it is necessary to repair or replace the components or the product.

Clabo Group will not accept any ulterior/ different responsibility and this includes direct and or indirect damages. Cases of replacement of the equipment will not lead to extension or renewal of the guarantee condition.

Transport and/or shipping costs of components or products delivered under guarantee or replaced faulty components returned to Clabo Group are to be covered by customer.

1.2 IDENTIFICATION

The SERIAL NUMBER on the plate positioned on the back (operator side) of the display cabinet (fig.1) must be given when contacting the manufacturer or customer services.



WARNING:

Maintenance of the good conditions and legibility of the label applied to the cabinet is recommended. Don't tamper with the label.

1.3 TECHNICAL ASSISTANCE

In case of malfunctioning of the machine, before contacting technical assistance, try to fix the problem following the troubleshooting guide reported in the chapter n.6.

If the problem cannot be fixed using the troubleshooting guide, contact the authorized technical assistance using one of the following references:

- Phone: 1.800.672.2784 | 510.441.0441
- Fax: 510.441.0401
- Email: sales@clabona.com

Or using Internet web site: www.clabona.com | www.otl-usa.com

It is necessary to communicate to the technical assistance:

- Cabinet serial number (as described in the previous paragraph)
- Cabinet Model, as reported in the label
- A detailed description of the problem encountered and of the interventions al right made to fix it.



ATTENTION:

Don't contact non-authorized technicians.

2. DATA AND TECHNICAL CHARACTERISTICS

2.1 MAIN CHARACTERISTICS

KT 24 Ice Cream Cabinet is designed for marketing and conservation of Ice Cream and so to reach in the refrigerated zone temperature not below -18/-20°C, achievable in environmental conditions not above Class 4 (ambient temperature 30°C, Relative Humidity 55%), defined on the European standard UNI EN 23953-2 par. 5.3.1.3.

As “refrigerated zone” is intended the region of the cabinet under the main worktop, highlighted by white lines on side glasses.

Cabinet thermal insulation with external ambient is obtained by Polyurethane Foam.

Cooling system is equipped with **semihhermetic** compressor; Condensing Unit is installed on the machine, in a vane housed in the basement or can be remote, within maximum 20mt of linear pipes far from the cabinet. In this case, cabinet and Condensing Unit are delivered separately and without cooling gas.



WARNING:

Installation and Gas Charge of cabinets with remote groups must be made by the customer. Please refer to the following chapters of the present manual.

The machine has an automatic defrosting cycle, regulated by an electronic control and by cooling cycle inversion.

Refrigeration is ventilated: inside the refrigerated zone there are fans that create air flow, responsible for ice cream cooling and conservation.

The machine is equipped with an electronic control board that manages the cooling system and the automatic defrosting, heating elements (to avoid water condensation problems) and lights. User interface is made by a 6-keys keyboard with a 3-digit display placed on the rooftop of the cabinet.

All glass surfaces are heated in order to avoid condensation problems. Front glass opens up with gas pistons that helps opening and sustain glass when opened, in order to permit cleaning operation.

The glass roof is supported by pillars in Plexiglas that can resist a maximum weight of 10 kg.



WARNING:

Don't put concentrated weight on the glass roof: *risk of Break*.
To avoid damages, distribute the weight evenly on the glass surface.

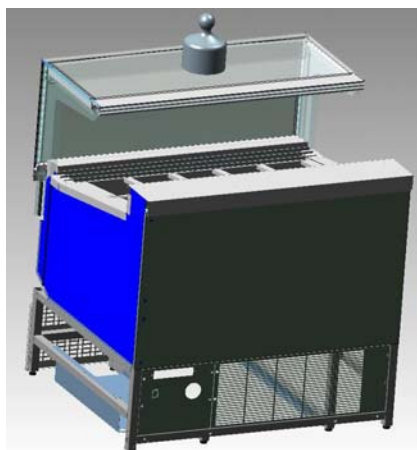

NO

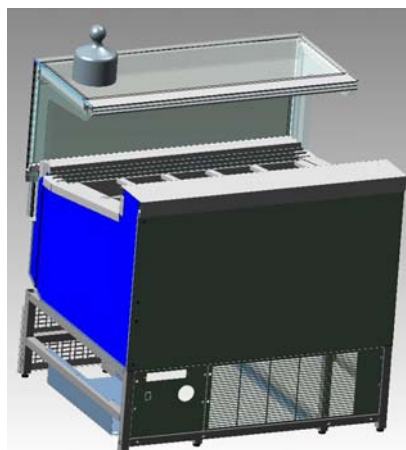

NO

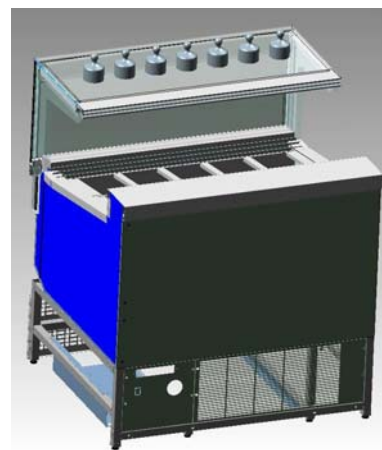

OK

2.2 TECH DATA

MODELS:		SUPPLY*: [V-PH-HZ]	COMPRESSOR POWER [W]	TOTAL POWER [W]	WORKING TEMPERATURE [°C]	GAS TYPE
H116	G6	400/3/50	1550	1610	-18/-20	R404A
	G9	400/3/50	2300	2290	-18/-20	R404A
	G12	400/3/50	2900	2890	-18/-20	R404A
	A30	400/3/50	1550	1710	-18/-20	R404A
	A45**	400/3/50	1200	2040	-18/-20	R404A
	C30	400/3/50	1550	1670	-18/-20	R404A

*: Other supply available on specific request

** : KT 24 A45 only with n.1 hermetic compressor and hot gas defrosting system

3. RECEIPT AND INSTALLATION

**WARNING:**

Before acceptance of the equipment, control the following:

- the package must be intact and the products haven't to be damaged during transport;
- the shipped goods correspond to the order specifications;
- the presence and integrity of accessories;
- possible damages occurred on products must be reported on the transport document for the compensation by the transport agency.

**WARNING:**

This product must be installed by qualified personnel. During installation the operators involved must wear individual protection devices.

**WARNING:**

The installation of Remote Condensing Units (where available), must be performed by qualified personnel, following the instruction reported on manual delivered with the condensing unit itself and supplied by the factory.

3.1 LIFTING AND MOVEMENT

The product is to be lifted by a transport vehicle using transport pallets, in the following manner:

- Position the forks at the level of the vehicle (e.g. lorry).
- Move forward with the transport pallet so as to insert the forks under the cabinet.
- Ensure that the cabinet is perfectly balanced on the forks before lifting it (fig.2).

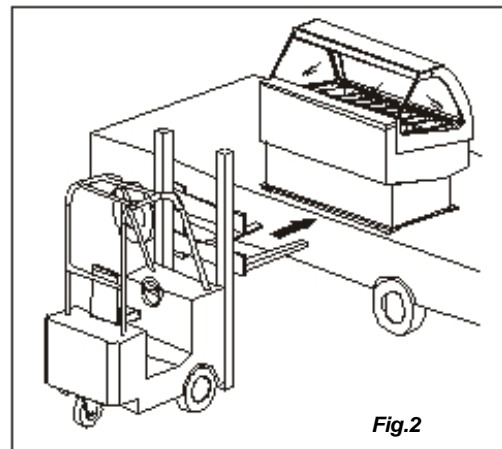
**WARNING:**

During the package unloading, using devices such as cutter could cause injuries to people or damages to product.

In addition, avoid to smear against the product with metallic parts such as watches, buckles, chains, rings and so on that could produce scratches.

- Position the cabinet on the ground.
- Lift the cabinet using the pallets as shown in figure 3.
- Unscrew the screws that anchor the lists to the base (fig.3 pos. A) and remove the base (fig.3 pos. B).
- Proceed in the same way to remove the other base.
- The cabinet must be moved manually when on the ground.

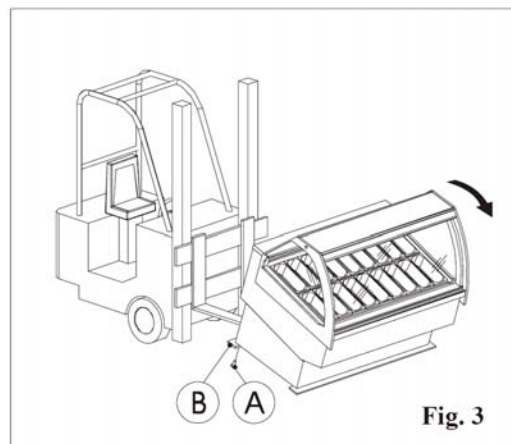

Fig. 3



WARNING:

TURN OVER OR SLIP DANGER

Don't lift the cabinet more than 10 cm above the ground.

3.2 POSITIONING

For a correct positioning follow these instructions:

- Position the cabinet in such a way as to leave sufficient space for use and maintenance in conditions of safety as foreseen by the UNI EN 12100-2010.
- Ensure the existence of a suitable earthing plant as foreseen by the European Norms.
- Once the cabinet is placed in the desired area, it must be put horizontally through the adjustable feet (fig.4).

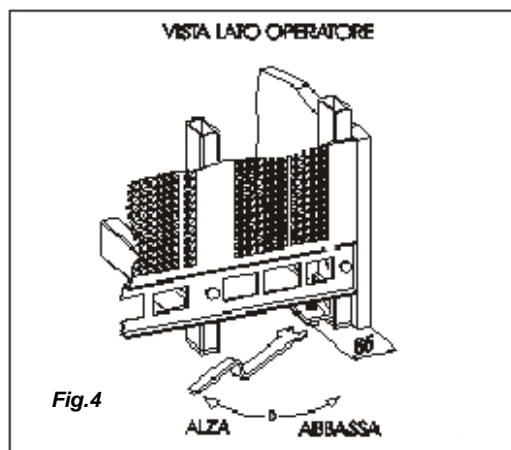

Fig.4



WARNING:

Before positioning the cabinet, assure that the floor is suitable for supporting its weight.

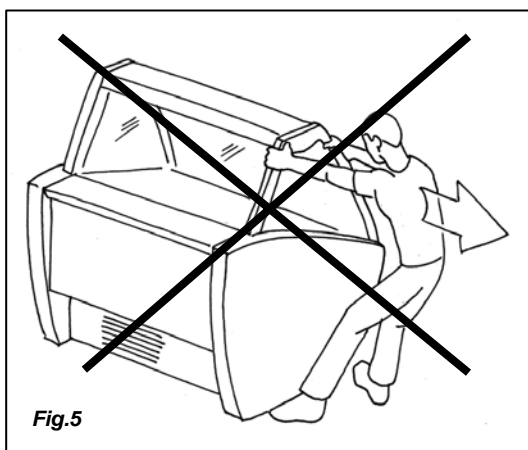

Fig.5



WARNING:

During positioning do not lean on or pull front and side glasses, front and side panels: *risk of damage* (see fig.5).

3.3 ENVIRONMENTAL CONDITIONS

When positioning the display cabinet take into consideration that its operability is guaranteed in the following environmental conditions: temperature $<30^{\circ}\text{C}$ and relative humidity $<55\%$. (class 4, UNI EN 23953-2).

It must also be checked that:

- there is sufficient circulation of air around the display cabinet but not strong currents;
- the display cabinet is not near any hot air sources;
- the display cabinet is not exposed to direct sunlight;
- the cooling air grills of the condenser are not blocked (fig. 6 , pos.A);
- air conditioning or heating in the room are not directed onto the display cabinet.

The above-mentioned indications must be respected to prevent malfunctioning, which will not be covered by the warranty.

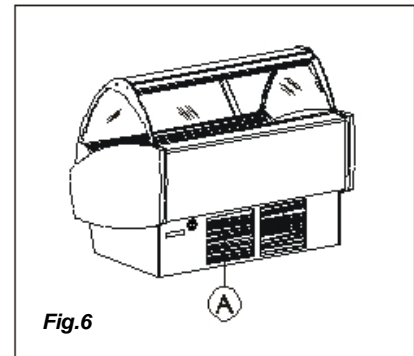

WARNING:

During working operations, there is an air exchange between the cabinet refrigerating system and the surrounding environment. For this reason don't install the cabinet in ambient subjected to pollution or having atmospheres with substances in concentration or quantity out of the limits regulated by actual law for health care.

3.4 CANALIZATION

Before performing canalization check that the showcases are at the same height by adjusting the special feet and that both showcases are laid flat, i.e. horizontally levelled.

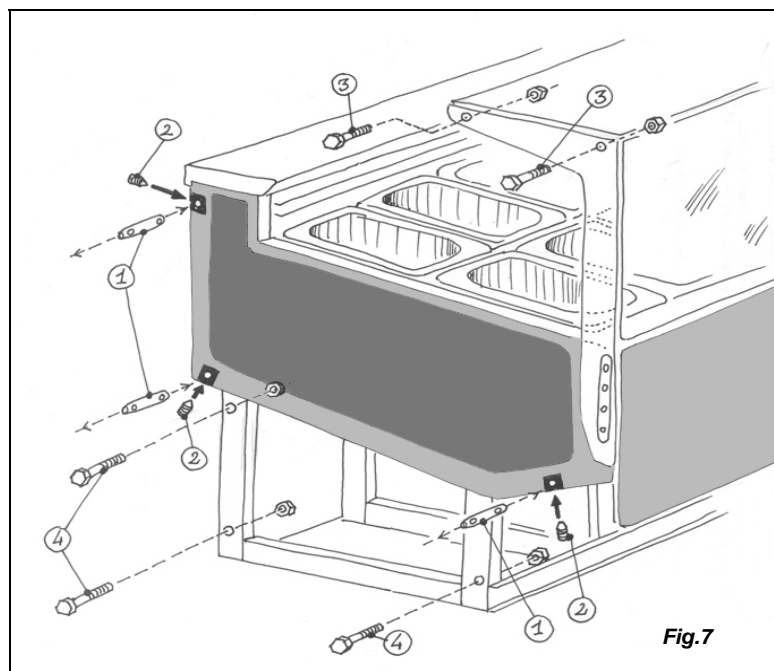

To carry out the showcase's canalization proceed as follows (Picture 7):

- insert pins n.1 and block them with screws n.2.;
- pull the two cabinets and join them using pins n.1 as references;
- block the pins on the second cabinet with screws n.2;
- insert screws n.3 on both rooftops and block them with nuts;
- insert screws n.4 on both bases and block them with nuts;
- insert divider glass in its hole between the two cabinets;

3.5 PLUMBING CONNECTIONS

Only for cabinets having water-cooled condenser or mixed condensation, it is necessary to connect the pipes of water inlet and outlet to the water supply. It is possible to recognize the inlet pipe because it is covered with black thermal insulation.



WARNING:

Before switching the cabinet on, be sure that the manual taps in the water line are open and the water flows regularly. Then calibrate the presso-static water valve in function of the water external net pressure and temperature.



WARNING:

Use of not-decalcified water could case irreparable damages to the system.
Use exclusively filtered and decalcified water.



WARNING:

Inlet water pressure can't exceed 10 bar.
Inlet water temperature shouldn't exceed 20°C in order not to decrease machine's performances.

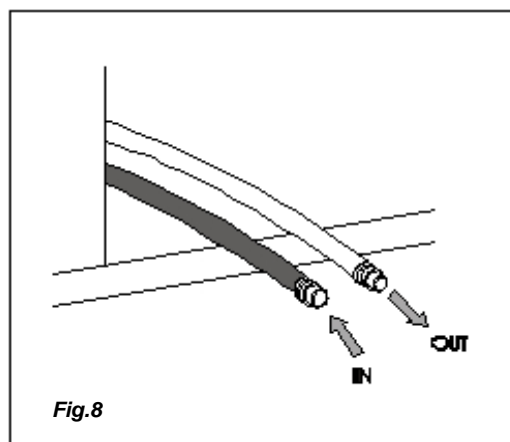

3.6 ELECTRICAL CONNECTIONS

Before installation, check that a suitable earth plant is present as envisioned by the regulations in force in the country of sale. Check that the mains voltage is compatible with the features stated on the plate positioned on the operator side of the display cabinet (see fig. 1). Also check that the line upstream from the display cabinet is appropriately dimensioned to support the load of the display cabinet itself.



WARNING:

Voltage fluctuation above 10% of the nominal voltage stated on the plate can cause permanent damage to the compressor and other electro-mechanical equipment. In this case they are not covered by the warranty.

Respect national regulations for electrical installations.

Position the master switch in the OFF position.

The display cabinet is supplied with a 5-wire cable;

- Yellow-green = Earth
- Blue = Neutral
- Brown = Live #1 (phase)
- Black = Live #2 (phase)
- Grey = Live #3 (phase)



WARNING:

Never cut or remove the yellow-green cable mentioned above: *risk of Electrical Shock*

The five supply cables must be connected to the main network, which must be equipped with an efficient earthing network, in accordance with the national and local norms (where existent) for electrical installations and they must be suitable for the electrical absorption of the display cabinet. Please refer to the table in correspondent chapter of the present manual, absorption column.



WARNING:

The electrical connection to the network must be carried out by means of the five wires included, the central plant to which the cabinet is connected must also have a switch with contact openings measuring at least 3mm and protected by fuses.



WARNING:

Apply an adequate anchoring method to the supply cable in the connection box, making reference to the table outlined below.

NOMINAL CURRENT [A]	NOMINAL SECTION [mm ²]	
	FLEXIBLE CABLES [mm ²]	CABLES FOR EARTHING [mm ²]
3	0,5 ÷ 0,75	1 ÷ 2,5
3 ÷ 6	0,75 ÷ 1	1 ÷ 2,5
6 ÷ 10	1 ÷ 1,5	1 ÷ 2,5
10 ÷ 16	1,5 ÷ 2,5	1,5 ÷ 4
16 ÷ 25	2,5 ÷ 4	2,5 ÷ 6
25 ÷ 32	4 ÷ 6	4 ÷ 10
32 ÷ 40	6 ÷ 10	6 ÷ 16
40 ÷ 63	10 ÷ 16	10 ÷ 25

3.7 WATER DRAINAGE

If the cabinet is supplied with external drain pipes for collecting water deriving from defrosting cycles or periodic cleaning, be sure to predispose adequate pipes connection to main sewer.

3.8 REMOTE COMPRESSOR(S) INSTALLATION

If condensing units are remote, they will be delivered on a separate crate. As standard these condensing units are suitable for installation up to 20mt far from the cabinet: by this specification different type of compressor will be delivered.

For installation, use and maintenance of remote condensing units please refer to the special manual delivered with the unit itself.

3.9 RAW CABINET COVERING

In case of cabinet ordered with raw finishing it is necessary to design the front panel/Cover in a way that the same can be removed easily in order to guarantee maintenance and technical service on front glass opening system.

3.10 END OF SERVICE AND DISPOSAL



Packaging

Do not throw away of part of the display cabinet packaging but separate it according to the type of material in question (cardboard, wood, steel, polyester, etc...) and dispose of it according to the current laws in vigour in the country of

use.

End of service of display cabinet

When the display cabinet has reached the end of its life span:

- Remove the refrigerant from the refrigerator circuit of the display cabinet.
- Empty it of all of the oil it contains.
- Remove all of the rubber parts (e.g. O-ring, rubber trimming).
- Send it off to be scrapped.

Important information for the User for the Purpose and effect of the WEEE Directive 2002/96/CE and subsequent amendments 2003/108/CE concerning Waste Electrical and Electronic Equipment: this equipment has been marked with the above crossed waste bin symbol.

The symbol of crossed waste basket reported on the machine or on the crate indicates that the product at the end of its life must be picked up separately from other waste. The dispose of machine must be done by specifically authorized WEEE disposal centre. User can find out information by its dealer / agent / manufacturer.

Disposal of the product without respecting the mentioned directives and standards means the application of sanctions provided for actual law.

4. FUNCTIONING

4.1 GENERAL USE RULES

The machine is designed for conservation of ice-cream at a temperature set by the customer but not below -18/-20°C.

Before introducing ice-cream in the cabinet it is necessary to wait **60 minutes** from the cooling start-up, in order to permit to the system to reach setpoint temperature. This interval of time could vary depending on environmental condition around the machine.



WARNING:

Displayed temperature is the value read by the cabinet probe: so this is the temperature of the air used for refrigeration. For this reason it could be different than the temperature of the conserved product.



WARNING:

It is very important to consider that the optimal temperature of the air varies considerably with the composition of ice-cream (in particular with the percentage of fats and sugars).



WARNING:

The conserved product must be introduced in the refrigerated region using suitable alimentary containers. If the conserved products exits from their containers, this cannot be sold or used: it must be removed and wasted.

For the correct functioning of the cabinet, it is necessary to verify that, during its operations, no ambient elements have an effect on its functioning; in particular it is necessary to control the follow:

- Air circulation around the cabinet should be sufficient to guarantee the correct functioning of the condenser (in case of inner condensing unit);
- For the same reason take care not to obstruct the back grid (staff's side) and the front one (if unit is on-board).
- No strong air currents or sources of hot air near the cabinet, that should interfere with inner ventilation, direct responsible for ice-cream cooling and maintenance at low temperature: this could lead to product melting.
- For the same reason eventual air conditioning or heating vents of the shop have not to be directed to the cabinet and interfere with inner ventilation.
- Direct sun light shouldn't hit the cabinet in any time. Sun radiation could damage the conserved product.



WARNING:

In case of damage of the conserved product, this one cannot be used or sold: it must be removed from the cabinet.

4.2 START UP

1. Operate the central electrical equipment's main switch.
2. Operate the showcase's main switch behind the back protection board. Remove the fixing screws from the back board, as shown in Picture 9 position B, and set the main switch on the "1" position (picture 9 position A) by activating the showcase's electrical power supply.

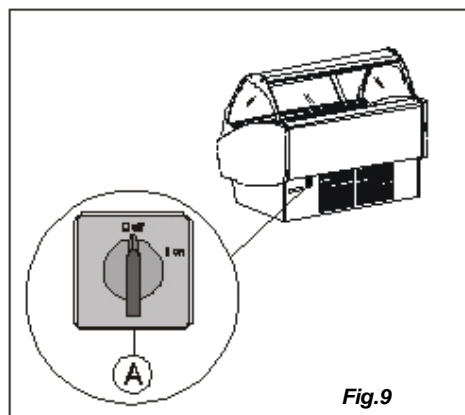







Fig.9





4.3 CONTROL BOARD













TASTIERA
T640 INOX BLUE
(183x38 MM)

-  To visualise or change the set point. When programming this button is used to select a parameter or to confirm a value.
-  This button is used during programming for going through the parameter codes or for increasing their value.
If pressed and then released you will visualise the controlled section (LOC, SE2, ALL).
If pressed continually for 3 seconds this button allows you to gain access to the sections menu.
-  This button is used during programming for going through the parameter codes or decreasing their value.
-  Keep this button pressed for 3 seconds to start the manual defrosting cycle.
-  Use this button to turn the display cabinet lights on and off.
-  Turn the cooling system on/off.

Keys Combinations:

-  +  Press and hold together for three seconds: enter the programming mode.
-  +  Press and release together : exit from programming and return to temperature visualization.

There are a series of luminous points on the display, the meaning of which you will find in the table below:

LED	Mode	Function
	ON	Compressor on
	FLASHING	Programming phase (flashing with LED )
	ON	Evaporator fans active
	FLASHING	Programming phase (flashing with LED )
	ON	Defrosting active
	FLASHING	Dripping time underway
	ON	Keyboard in "ALL" mode
	FLASHING	Keyboard in RVD mode (remote control)
	ON	ALARM SIGNAL - In the "Pr2" programme it indicates that the parameter is also present in "Pr1"

4.4 VISUALIZE MINIMUM RECORDED TEMPERATURE



Press and release key .

"LO" message will be visualized on display, followed by the minimum temperature recorded. Press again  key or wait 5 seconds in order to visualize standard read temperature.

4.5 VISUALIZE MAXIMUM RECORDED TEMPERATURE





Press and release key .

"HI" message will be visualized on display, followed by the maximum temperature recorded. Press again  key or wait 5 seconds in order to visualize standard read temperature.

4.6 RESET MINIMUM / MAXIMUM RECORDED TEMPERATURE



In order to reset recorded temperatures, first visualize maximum/minimum recorded temperature as described above, with keys  or .

Push SET button until the message "Rst" on display flashes three times.

4.7 SETPOINT VISUALIZATION AND CHANGE



Press and release the **SET** key: Setpoint temperature will be immediately visualized. Wait 15 second to come back to normal visualization.

Press and hold the **SET** button for more than 3 seconds to change setpoint value: the * led starts to flash.

Modify the value using ▼ and ▲ keys.

Memorize the new set value pressing again **SET** button. The value will flash. Wait at least 15 seconds to exit from setpoint programming mode.

4.8 MANUAL DEFROSTING CYCLE



Press and Hold Defrosting Button for more than 3 seconds: the label “dF1” will appear on display; push SET button to start defrosting.

4.9 STAND-BY FUNCTION



Pressing **ON/OFF** key, “**OFF**” will be displayed.

When **OFF** is displayed the machine enters the “Stand-by” mode and all loads and regulation are disabled. Press again **ON/OFF** button to exit the Stand-by mode.

Note: During Stand-by mode the light switch is active.





4.10 LOCAL ALARMS

Display	Cause	State of Outputs
P1	Thermostat probe failure	Output according to “ Con “ and “ COF “ parameters
P2	Evaporator probe failure	Unchanged
P3	Auxiliary probe failure	Unchanged
HA	High temperature alarm	Unchanged
LA	Low temperature alarm	Unchanged
EE	Memory anomaly	
EAL	Digital input alarm	Unchanged
BAL	Blockage alarm from digital input	Regulation outputs deactivated
rtc	Clock alarm	Unchanged
rtF	Clock alarm failure / not present	Alarm output active, other outputs unchanged.





4.11 RESERVE CONTROL PANEL



TASTIERA
T640 INOX BLUE
(183x38 MM)

-  To visualise or change the set point. When programming this button is used to select a parameter or to confirm a value.
-  This button is used during programming for going through the parameter codes or for increasing their value.
If pressed and then released you will visualise the controlled section (LOC, SE2, ALL).
If pressed continually for 3 seconds this button allows you to gain access to the sections menu.
-  This button is used during programming for going through the parameter codes or decreasing their value.
-  Turn the cooling system on/off.

Keys Combinations

-  +  Press and hold together for three seconds: enter the programming mode.
-  +  Press and release together : exit from programming and return to temperature visualization.

There are a series of luminous points on the display, the meaning of which you will find in the table below:

LED	Mode	Function
❄	ON	Compressor on
❄	FLASHING	Programming phase (flashing with LED ❄)
🔊	ON	ALARM SIGNAL - In the “Pr2” programme it indicates that the parameter is also present in “Pr1”

4.12 RESERVE SETPOINT VISUALIZATION AND CHANGE



Press and release the **SET** key: Setpoint temperature will be immediately visualized.

Press and hold the **SET** button for more than 3 seconds to change setpoint value: the * led starts to flash. Modify the value using ▼ and ▲ keys. Memorize the new set value pressing again **SET** button. The value will flash. Wait at least 15 seconds to exit from setpoint programming mode.

4.13 LOCAL ALARMS

Display	Cause	State of Outputs
P1	Thermostat probe failure	Output according to “ Con “ and “ COF “ parameters
P2	Evaporator probe failure	Unchanged
P3	Auxiliary probe failure	Unchanged
HA	High temperature alarm	Unchanged
LA	Low temperature alarm	Unchanged
EE	Memory anomaly	
EAL	Digital input alarm	Unchanged
BAL	Blockage alarm from digital input	Regulation outputs deactivated
rtc	Clock alarm	Unchanged
rtF	Clock alarm failure / not present	Alarm output active, other outputs unchanged.

4.14 CABINET WITH INDEPENDENT SECTOR (“FRUTTINI”)

If the cabinet is equipped with a second independent sector (generally called “*Fruttini*”) with a different temperature setpoint, the machine is equipped with an additional electronic control, having same kind of display and use. In this case it is possible to set a different temperature between main sector and fruttini and/or turn off one of the sectors leaving the other one functioning.

Defrosting of the two sectors is simultaneous for system reasons: so the automatic defrosting cycle will occur together also if the two sector are turned on/off in different times.



WARNING:

For reasons regarding cooling system, turning off main sector leaving the second sector “fruttini” functioning means that the last one has less autonomy and should be turned off every day, at the end of daily service.

4.15 OPTIONAL KIT KVP – ICE CREAM / PASTRY CHANGE

The cabinet could be equipped with the so called “Kit KVP”, as optional: it is an additional systems of valves that permit to operate the cabinet designed for ice cream products also for positive temperature.

Acting on the additional switch the system adapts to work in different conditions and in this way it is possible to set the temperature up to +4°C.

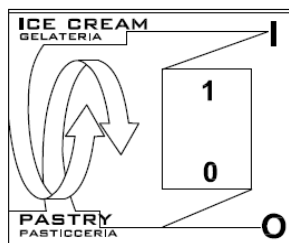

In order to use the optional for passing from ice-cream functioning to pastry functioning, identify additional switch located in cabinet back panel and highlighted by the sticker shown here

The presence of the light of the switch (pos.1) means that the cabinet is working in Ice-Cream Mode. On the other hand the switch off (position 0) identify the pastry functioning.



WARNING:

Activating the switch for passing in Pastry mode the programming parameter of the control board are NOT changed: for this reason the cabinet will continue to work with same settings of Ice Cream functioning (i.e. it will defrost at the same intervals).

Temperature Setpoint MUST be changed manually, increasing it to +4°C: if this operation is omitted the compressor will never stop with consequent possible damage..

4.16 STOPPING THE MACHINE

To stop the cooling system operate the switch, which is located behind the rear protection panel. Position the master switch at “0” (fig.9) disconnecting the display cabinet power supply.

5. CLEANING AND MAINTENANCE



WARNING:

All maintenance operations must be performed by expert qualified personnel. Before performing any maintenance operation be sure that the cabinet is disconnected from electrical supply.



WARNING:

Wait until hot parts have cooled down and reached ambient temperature to avoid burning risk.



WARNING:

Wear suitable gloves during maintenance and cleaning operations to avoid contact with metallic parts which could cause injuries.

5.1 ORDINARY MAINTENANCE: DAILY CLEANING

Daily cleaning operations can be performed by generic not-trained personnel. Glass and working surfaces should be cleaned every day, at the end of the daily service of the shop.

**WARNING:**

During daily cleaning operations, remove completely the conserved product from the cabinet. In case of possible contacts between the displayed products and not-alimentary chemicals, the product should be removed and wasted: it can't be used or sold.

Glass surfaces:

Clean glass surfaces (back door, front and side glasses, shelves and roof top) using a humid sponge and a specific cleaner for glasses. Remove with care any residual of cleaners or chemicals, drying with a soft cloth.

**WARNING:**

During moving glass cleaning operation, open and close them with great care accompanying them until end of movement. Avoid to lean on movable glasses during cleaning operations.

Plastic / Stainless Steel / Wood / Marble / Chromate surfaces:

Clean with a sponge or humid cloth, using water and/or neutral specific cleaners; wash and dry with care using a soft cloth.

5.2 ORDINARY MAINTENANCE : WEEKLY CLEANING

Weekly cleaning operations can be performed by generic not-trained personnel.

Cabinet must be completely cleaned at least once a week, in order to eliminate dirt and to defrost it completely. If the environment is hot and humid a more frequent cleaning is advised.

Remove bottom panel for performing weekly cleaning, in order to get access to the bottom of the basin.

Do the following:

1. Remove containers or trays with conserved product from the cabinet.
2. Turn off the cabinet and disconnect it completely from the electrical net.

**WARNING:**

Before performing any weekly cleaning operation, be sure that the cabinet is turned off and completely disconnected from electrical net.

3. Remove internal movable panels. Clean them with care using neutral cleaners; wash them with water and dry using a soft cloth.

**WARNING:**

Removing bottom panels you will get free access to the evaporators surfaces which are sharp and could injury the staff: wear always suitable gloves when performing weekly cleaning.

4. Use a humid sponge to remove any residual of conserved product and dirt from the basin. Avoid using too much water that could damage electric components.

**WARNING:**

Don't tamper or damage electrical connections and wires or the refrigerating system piping, inside and below the basin.

5. Clean the basin with a dry cloth and let it dry completely.
6. Put all the bottom panels back in place as they were positioned before.
7. Turn on the cabinet again.

**WARNING:**

Use of abrasive, corrosive products, solvents, acids that could cause irreparable damages on surface and start corrosion must be avoided.

Don't pour flammable products on hot parts such as lamps, LEDs, ballasts and so on.

Don't pour water on electric components such as fan motors, lights and so on..

**WARNING:**

In case of Electric water-evaporating pans optional don't use too much water during cleaning operations in order to avoid water spillage on floor.

**WARNING:**

During cleaning operations of movable glasses, be careful in opening and closing the glass, accompanying it until its final position. Avoid to lean on the open glass during cleaning phases.

5.3 PROGRAMMED MAINTENANCE – CONDENSER CLEANING

Condenser cleaning must be performed by an expert and qualified operator, for it is considered a programmed maintenance operation.

The deposit of dust and dirt in general on the condenser fins (air) reduces the efficiency of the plant until functioning is prevented and causing damage to the compressor. It is therefore absolutely necessary to periodically clean the condenser (every 20-30 days) as indicated below:

1. Turn off the cabinet and disconnect it from the electrical net.
2. Remove the back protection grid.
3. Remove dust and dirt present on the condenser fins using a brush or a vacuum cleaner (fig.10)

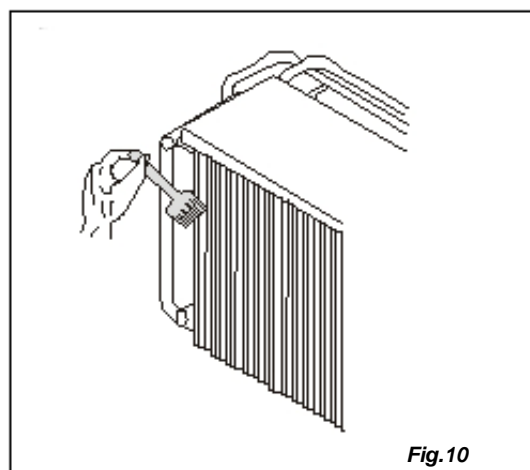
**WARNING:**

During condenser cleaning operations don't use rigid or metallic objects that could damage it.

5.4 SUMMARY OF SCHEDULED MAINTENANCE

Ordinary Maintenance				
	Generic Operator	Qualified Operator	Frequency	Tools
External glass surfaces	X		Daily	Suitable cleaner,, Humid sponge
Internal Glass surfaces	X		Daily	Suitable cleaner,, Humid sponge
Other External surfaces	X		Daily	Suitable cleaner,, Humid sponge
Inner basin surfaces	X		Weekly	Humid Sponge

Programmed Maintenance				
	Generic Operator	Qualified Operator	Frequency	Tools
Condenser Cleaning		X	Monthly	Brush / Vacuum Cleaner

6. PRACTICAL TROUBLESHOOTING GUIDE

1) Temperature of the display area not low enough (i.e. ice cream too soft)

<i>Probable Cause</i>	<i>Probable Solution</i>
Evaporator closed by ice	Perform a complete defrost as follow: Remove the conserved product and put inside another refrigerated cabinet. Turn off main switch for 10/12 hours in order to permit the complete melting of frost inside the cabinet.
Condenser blocked by dust or other.	Clean the condenser. Remove everything that obstructs regular air flow to the condenser.
The ventilators are not working and / or their blades are damaged.	Request the intervention of the assistance service for the replacement of the same.
The display cabinet is exposed to air currents or direct sunlight	The display cabinet does not function in these conditions; remove the display cabinet from the air currents and/or direct sunlight
The thermostat is not working properly. With a perfectly functional refrigerating plant, the thermostat maintains a higher temperature in the air than that set.	Call the technical assistance service.
The refrigerated airflow (the “sheet of air”) on the ice-cream is irregular.	Check the air circuit (ventilator area, area beneath the evaporator) and remove any obstacles to the circulation of cold air.
Lack of water	Check if there is a water flow, if there is, call the technician for possible water valve rupture, presso-stat problems or other causes.

2) The defrosting water does not drain off properly (that is, the water obtained from the melting of ice during the automatic or manual defrosting phases).

<i>Probable Cause</i>	<i>Probable Solution</i>
The defrosting water drainage tube that goes from the cold tub to the tub in which such water is channelled (for evaporation) is blocked.	Open up the drainage tube
The display cabinet is positioned on the ground in such a way that the drainage water is not directed towards the outlet hole.	Ensure that the display cabinet is level on the ground. It must be completely level.

3) The compressor never stops or it works for very long periods of time.

<i>Probable Cause</i>	<i>Probable Solution</i>
The room temperature is very high (e.g. above +32°C).	If it is not possible to lower the room temperature (e.g. by means of air conditioning) the compressor will work almost constantly.
The air condenser is blocked	Clean the condenser
The thermostat is set too low.	Regulate the thermostat to a higher temperature
The ventilators are off.	Call the assistance service to individualise the cause and replace them if necessary.

4) The display cabinet does not work

<i>Probable Cause</i>	<i>Probable Solution</i>
The cabinet is not plugged in.	Plug it in
The trip switch has gone off.	Reinsert the trip switch.
The general switch of the display cabinet is off.	Turn on the general switch of the display cabinet

5) The light is not working

<i>Probable Cause</i>	<i>Probable Solution</i>
The light switch is not turned on.	Turn on the light switch
The fluorescent light bulb is not inserted properly.	Insert the light bulb properly.
The light bulb is blown.	Replace the light bulb
The “starter” is blown.	Replace the “starter”

7. ELECTRICAL DRAWINGS (STANDARD VERSION)

7.1 ELECTRICAL DIAGRAM KT 24 G6-G9-G12-A30-C30 (1 SEMIHERMETIC COMPRESSOR)

Std Ver. 400-3-50

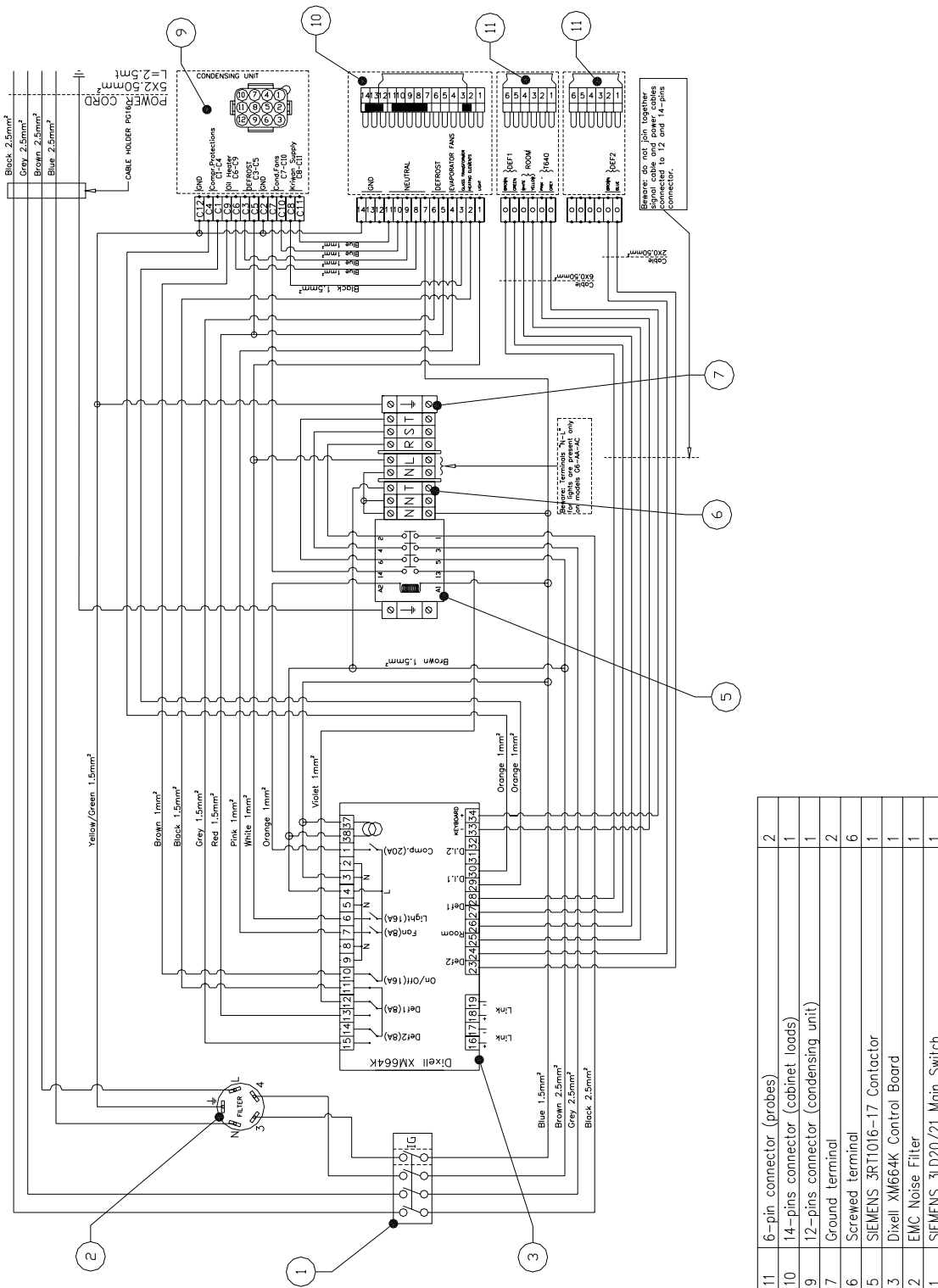

7.2 ELECTRICAL DIAGRAM KT 24 A45 (1 HERMETIC COMPRESSOR – HOT GAS SYSTEM DEFROST)

Std Ver. 400-3-50

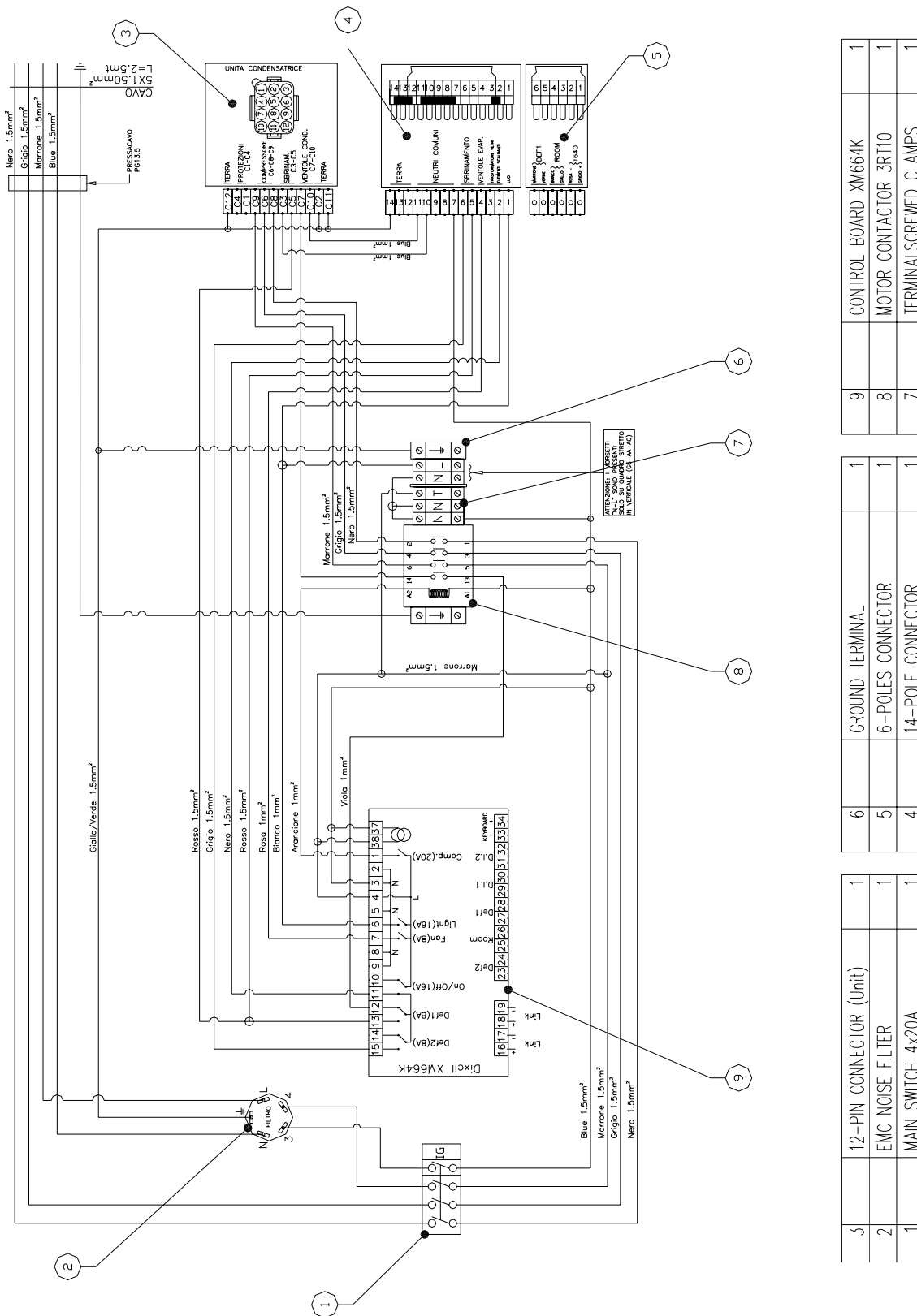

7.3 LIGHT CONNECTIONS

LED LIGHTS

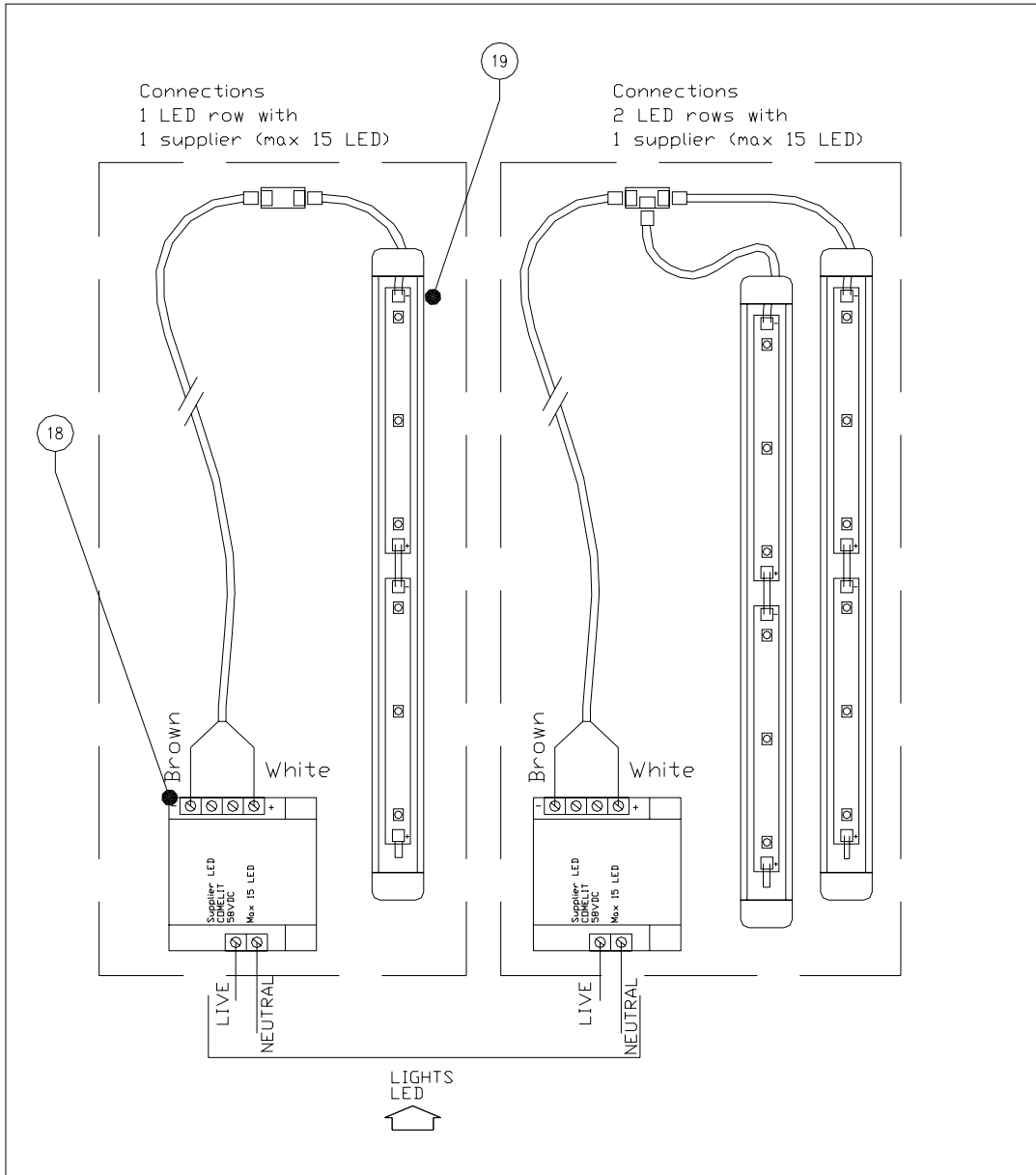

N	Descrizione
18	LED Supplier(Max 15)
19	Aluminium LED Bar

7.4 CONDENSING UNIT CONNECTION BOX (INTERNAL OR REMOTE UNIT)

Std Ver. 400-3-50

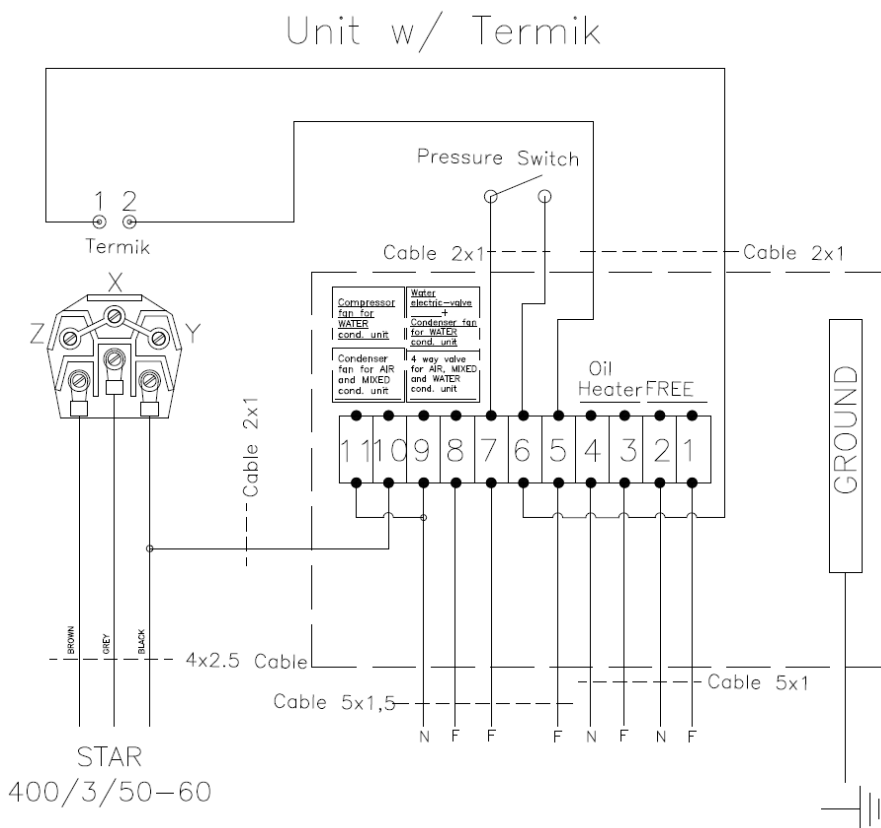
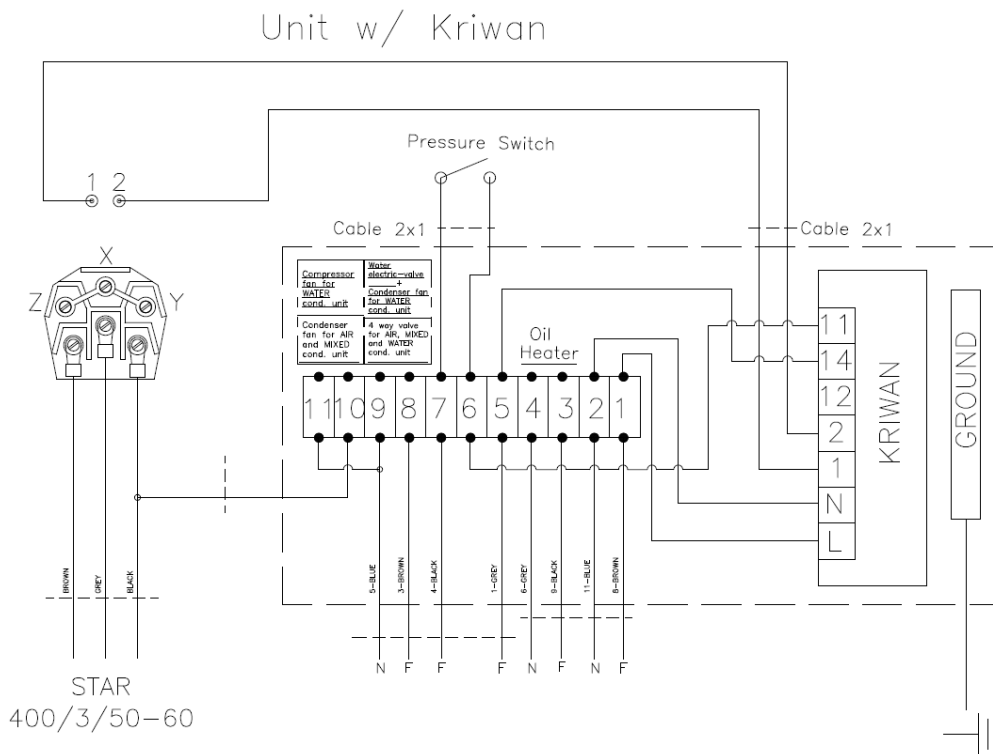

8. COOLING SYSTEMS DIAGRAMS

8.1 COOLING SYSTEM W/ CYCLE INVERSION DEFROST – G6-G9-G12-A30-C30

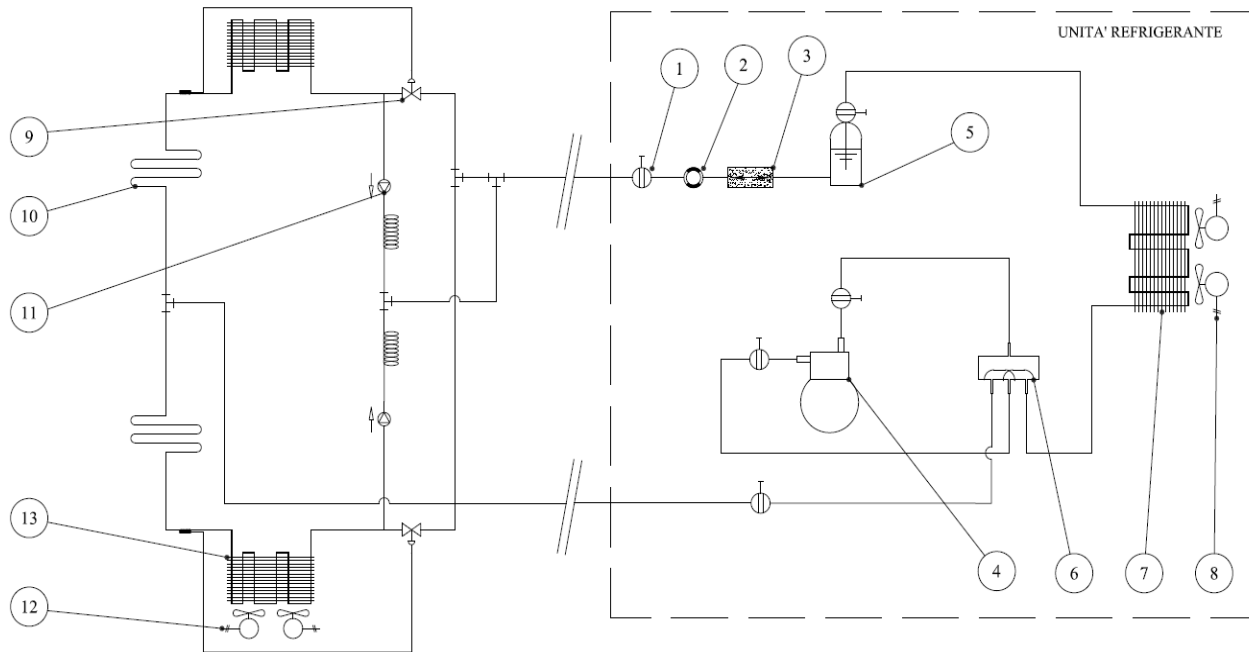

Position	Description	Q.ty
1	Manual Tap	1
2	Spy Glass	1
3	Filter	1
4	Compressor	1
5	Liquid receiver	1
6	4-way Inversion Valve	1
7	Condenser	1
8	Condenser Fan(s)	2
9	Thermostatic Valve	2
10	Basin Defrosting Copper Coil	2
11	One-Way Valve	2
12	Evaporator Fans	3-5
13	Evaporator(s)	2

8.2 COOLING SYSTEM W/ HOT GAS DEFROST – A45

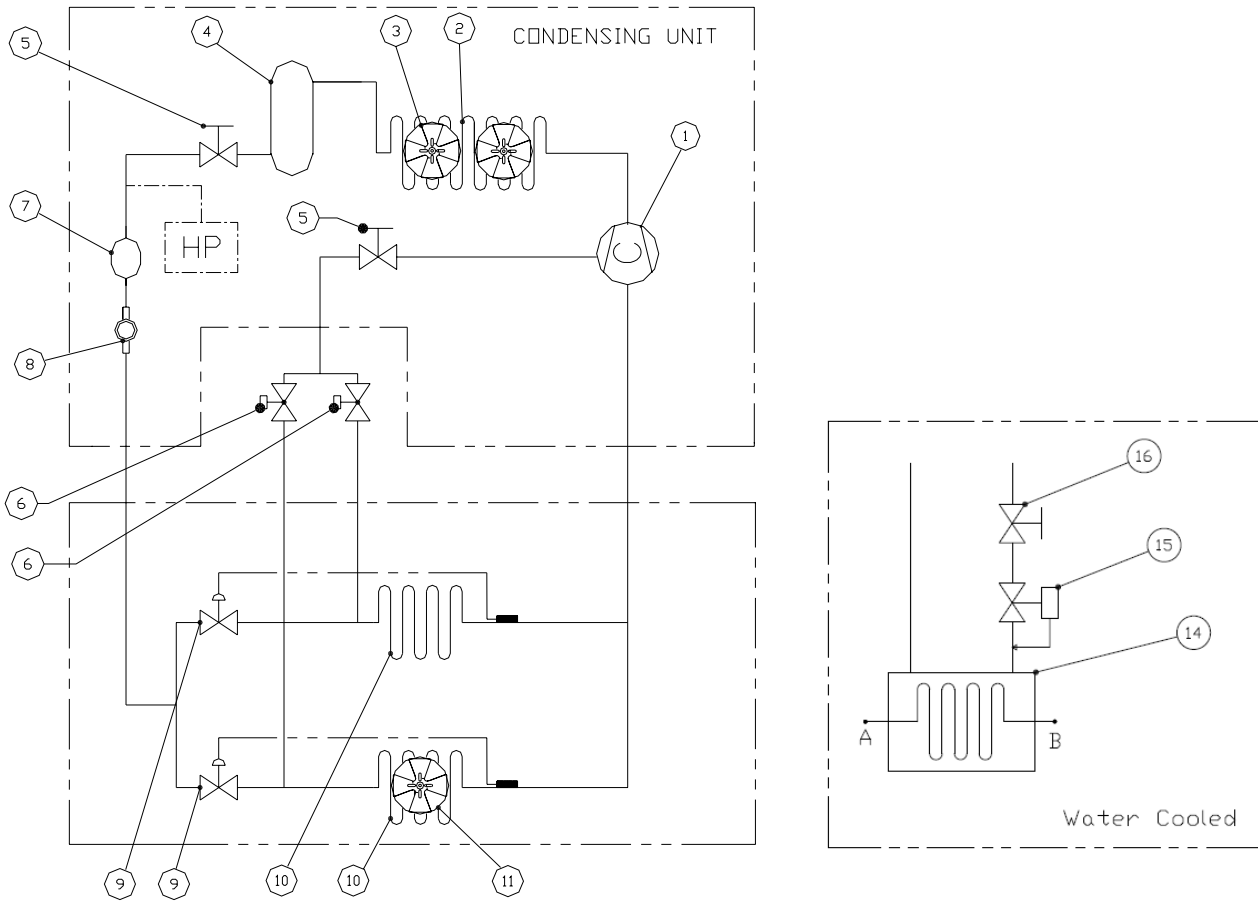

POS.	Description	Q.tà
1	Compressor	1
2	Condenser	1
3	Condenser Fans	1
4	Liquid Receiver	1
5	Ball Valve	2
6	Hot Gas Defrost Solenoid Valve	1
7	Filter Drier	2
8	Liquid Indicator	2
9	Thermostatic Valve	2
10	Evaporator	1
11	Evaporator Fans	1
<i>Optional condensazione ad acqua</i>		
14	Water Cooled Condenser	1
15	Water Pressure Valve	1
16	Water Inlet Manual Tap	1

8.3 OPTIONAL KIT KVP – PASTRY / ICE CREAM PASSAGE

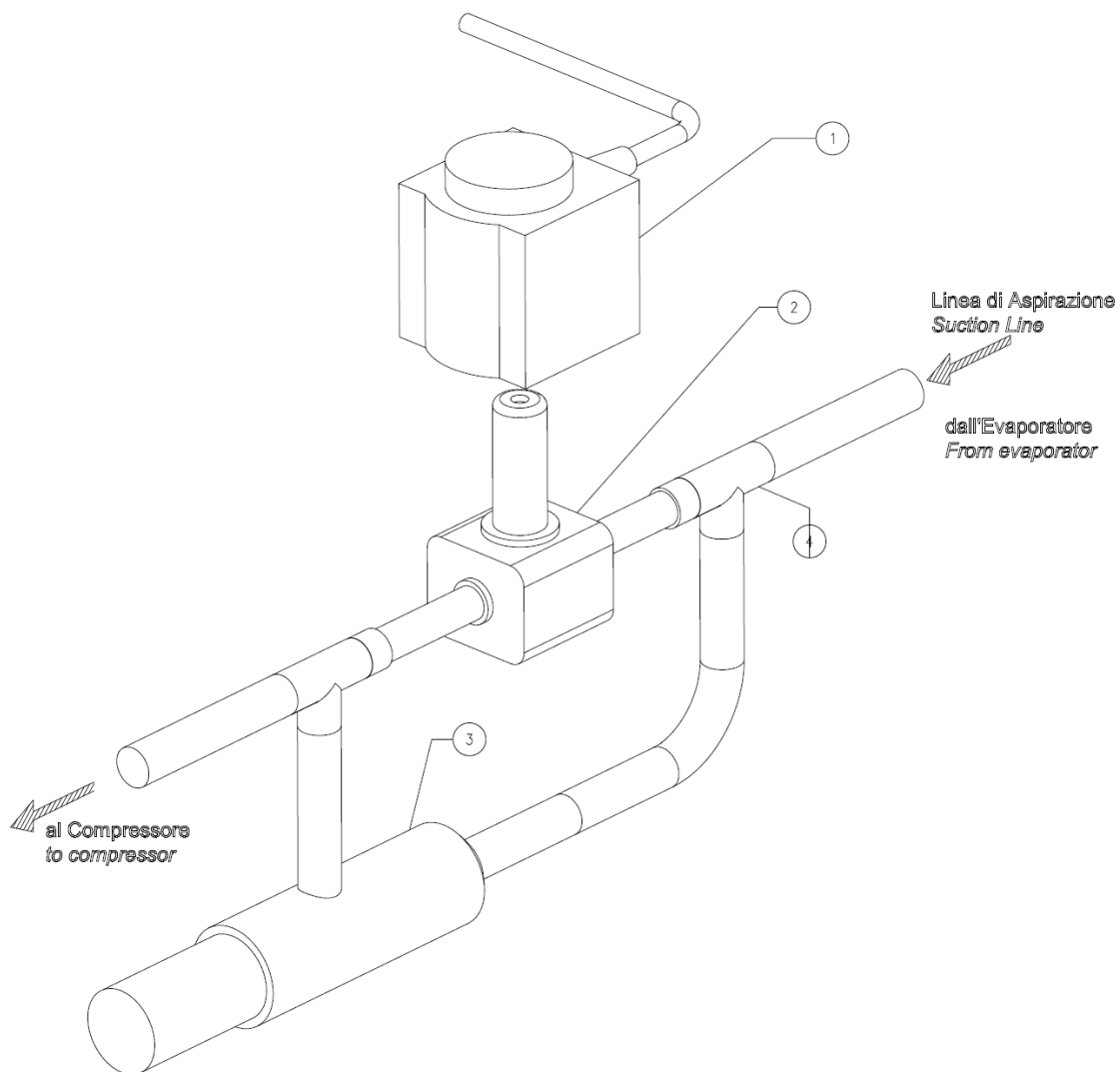

N	Description
1	Solenoid Valve Coil
2	Solenoid Valve Body
3	KVP Pressure Regulating Valve
4	Tee



33300 Central Avenue | Union City, CA 94587
Tel: 1.800.672.2784 | 510.441.0441 | Fax: 510.441.0401
www.clabona.com | www.otl-usa.com E-mail: sales@clabona.com



60035 JESI (An) Italy - ZIPA -Viale dell'Industria
Tel. +39 0731 61531 – Fax +39 0731 6153413
www.clabogroup.com - E-mail: info@clabogroup.com