



SACHER

PASTRY CABINET

Index

1	STANDARDS AND REGULATIONS	3
1.1	Warranty:.....	3
1.2	Environmental notes:.....	3
1.3	Identification:.....	3
2	INSTALLATION	4
2.1	Lifting and Movement:.....	4
2.2	Positioning:.....	4
2.3	Environmental Specifications:.....	5
2.4	Hydraulic connection:.....	5
2.5	Electrical Connection:.....	6
3	FUNCTIONING.....	7
3.1	Start-up:.....	7
3.2	Command Console:.....	7
3.3	Keyboard.....	7
3.4	The meaning of the leds.....	8
3.5	How to visualise and change the set point.....	8
3.6	How to set up a manual defrosting cycle.....	8
3.7	The ON/OFF Function.....	8
3.8	Local Alarms.....	9
3.9	Automatic defrosting.....	9
3.10	Stopping the Machine:.....	9
4	PRALINE (OPTIONAL).....	10
4.1	Humidity control.....	10
4.2	Use of Leds.....	10
4.3	To see and change the Set Point.....	10
4.4	Alarm signals.....	10
5	MAINTENANCE.....	11
5.1	Preliminary Operations:.....	11
5.2	Cleaning the condenser:.....	11
5.3	Periodical defrosting:.....	11
5.4	General Cleaning:.....	11
6	PRACTICAL TROUBLESHOOTING GUIDE.....	12
7	ELECTRICAL DIAGRAMS.....	14
8	REFRIGERATOR PLANT DIAGRAM.....	16

Rev. 21/08/2008

DEAR CUSTOMER

For the safety of the operator, the display cabinet devices must be kept efficient. The aim of this manual is to explain use and maintenance of the display cabinet. The operator is responsible for ensuring that instructions are followed. No other use of the display cabinet is allowed other than that indicated in this manual.

1 STANDARDS AND REGULATIONS

1.1 Warranty:

The validity of the warranty is certified by the purchase receipt and the label attached to the tag on the product stating the bar and alphanumeric codes. This documentation must be kept in a safe place and must be stated or shown if requests for interventions are made whilst under guarantee. The warranty does not cover any damage caused during transport by third parties, by incorrect installation and maintenance, by negligence or carelessness of use and tampering by third parties. To obtain a technical intervention under guarantee, a written request must be sent to the Sales Direction or to the nearest dealer.

Clabo Group at their own discretion will decide whether to repair or replace the component or the entire appliance.

Clabo Group rule out any further responsibility also regarding direct and/or indirect damage. If the display cabinet is replaced the warranty period is not renewed or prolonged.

1.2 Environmental notes:

- Packaging

Do not throw away the packaging but separate the different types of material (cardboard, wood, steel, polyester etc.) and dispose of them in compliance with the regulations in force in the country where the display cabinet is to be used.

- Display cabinet out of service

At the end of the display cabinet's life span:

- Remove the refrigerant from the display cabinet refrigerant circuit.
- Empty all oil and remove all rubber parts (e.g. O-ring, gaskets)
- The display cabinet must be sent for destruction.



IMPORTANT INFORMATION FOR USERS ACCORDING TO ART.13 LEGISLATIVE DECREE JULY 25, NO. 151 "ACCOMPLISHMENT OF DIRECTIVES 2002/98/CE, 2002/90/CE AND 2003/108/CE, CONCERNING THE REDUCTION OF THE USE OF DANGEROUS SUBSTANCES IN ELECTRIC AND ELECTRONIC EQUIPMENT, AS WELL AS THE WASTE DISPOSAL".

The sign of the crossed bin on the equipment or on its packing indicates that the product must be gathered separate from other waste at the end of its life. The equipment waste disposal must be accomplished using the RAEE waste disposal centres specifically authorized. Users can contact their jobber/distributor/producer for information. The correct separate collection and subsequent recycling, treatment and the environment-friendly disposal of the equipment helps to prevent possible negative effects on the environment as well as health problems and promotes the re-employment and/or recycling of the equipment components. The product disposal without respecting the law implies the enforcement of administrative sanctions provided for by the rule in force.

1.3 Identification:

The SERIAL NUMBER on the plate positioned on the back (operator side) of the display cabinet (fig.1) must be given when contacting the manufacturer or customer services.

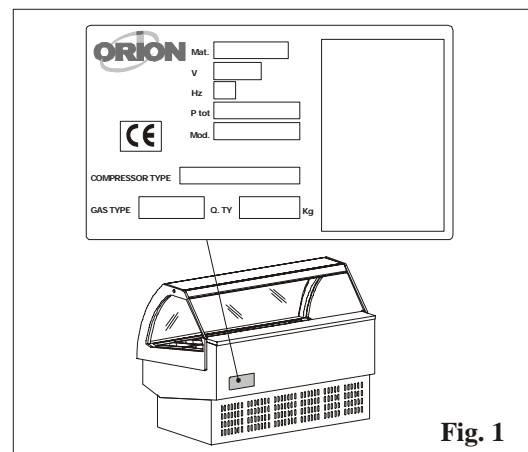

Fig. 1

2 INSTALLATION



This product must be installed by qualified personnel.

2.1 **Lifting and Movement:**

The product is to be lifted by a transport vehicle using transport pallets, in the following manner:

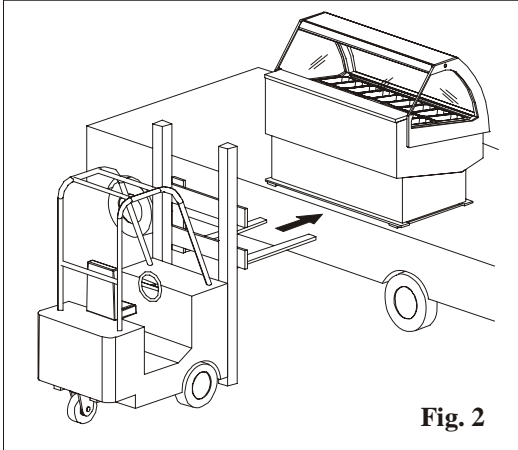

- Position the forks at the level of the vehicle (e.g. lorry).
- Move forward with the transport pallet so as to insert the forks under the cabinet.
- Ensure that the cabinet is perfectly balanced on the forks before lifting it (fig.2).

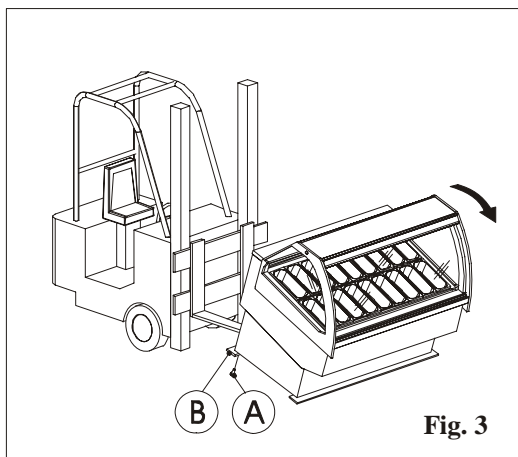

- Position the cabinet on the ground.
- Lift the cabinet using the pallets as shown in figure 3.
- Unscrew the screws that anchor the lists to the base (fig.3 pos. A) and remove the base (fig.3 pos. B).

Proceed in the same way to remove the other base.

The cabinet must be moved manually when on the ground.

2.2 **Positioning:**

Please carry out the following operations to ensure correct positioning:

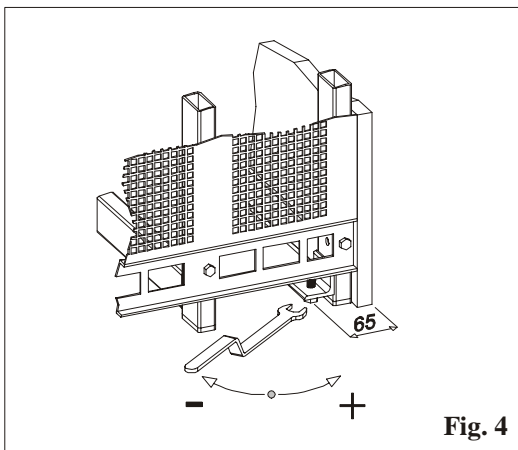

- Position the display cabinet leaving enough space for use and maintenance in safe conditions as envisioned by the UNIEN 292/2 Standard point 6.2.1 and in paragraph 2.6
- Check that there is a suitable earth plant present envisioned by European Standards.
- Once positioned in the desired area, make the display cabinet level using the adjustable feet (fig. 4).

2.3 Environmental Specifications:

When positioning the display cabinet take into consideration that its operability is guaranteed in the following environmental conditions: temperature $<30^{\circ}\text{C}$ and relative humidity $<55\%$.

It must also be checked that:

- there is sufficient circulation of air around the display cabinet but not strong currents;
- the display cabinet is not near any hot air sources;
- the display cabinet is not exposed to direct sunlight;
- the cooling air grills of the condenser are not blocked (fig. 5 pos. A);
- air conditioning or heating in the room are not directed onto the display cabinet.

The above-mentioned indications must be respected to prevent malfunctioning, which will not be covered by the warranty.

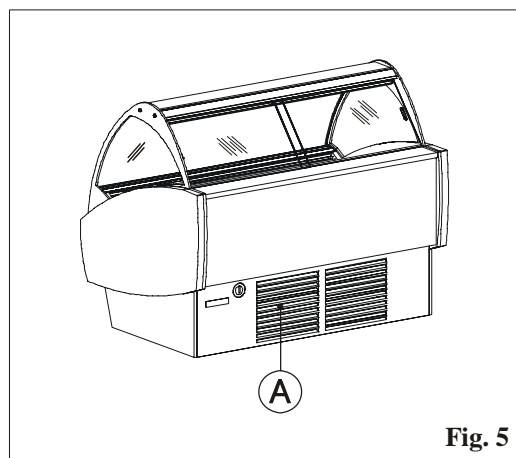

Fig. 5

2.4 Hydraulic connection:

For the display cabinets with water-cooled condenser the inlet and outlet pipes must be connected to the mains water system. The inlet pipe can be recognised as it is covered by heat insulation.

ATTENTION! Before using the display cabinet make sure taps are open and that water flows regularly (fig. 6).

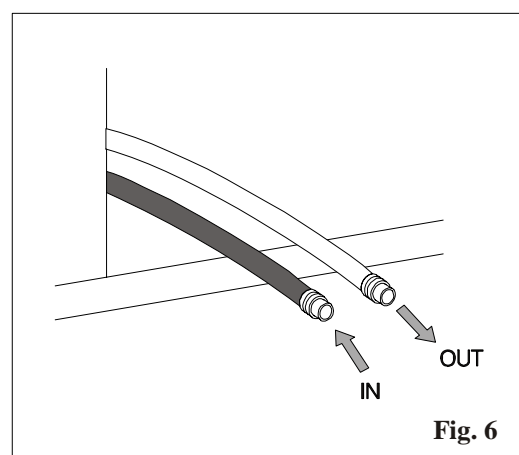

Fig. 6

2.5 Electrical Connection:

Before installation, check that a suitable earth plant is present as envisioned by the regulations in force in the country of sale. Check that the mains voltage is compatible with the features stated on the plate positioned on the operator side of the display cabinet (see fig. 1 page 3). Also check that the line upstream from the display cabinet is appropriately dimensioned to support the load of the display cabinet itself.

ATTENTION! Voltage fluctuation above 10% of the nominal voltage stated on the plate can cause permanent damage to the compressor and other electro-mechanical equipment. In this case they are not covered by the warranty.

Respect national regulations for electrical installations.

Position the master switch in the OFF position.

The display cabinet is supplied with a 3-wire cable;

Yellow-green = Earth

Blue = Neutral

Brown = Phase

ATTENTION! Never cut or remove the yellow-green cable mentioned above.

The three power supply wires must be connected to the back-bone network, which has a safe efficient earth system, in compliance with national and local regulations (where present) regarding electrical installations and suitable for the electric absorption of the display cabinet, refer to chapter 6 – Total Absorbed Power.

ATTENTION! The electrical connection to the mains must be made using the three wires supplied. Moreover, the central plant to which the display cabinet is connected must have a switch with contact opening of at least 3 mm protected by fuses.

ATTENTION! Apply a suitable method of fixing to the power supply cable on the connection box, making reference to the table shown below.

APPLIANCE NOMINAL CURRENT [A]	NOMINAL SECTION [mm ²]	
	FLEXIBLE CABLES [mm ²]	EARTH CABLES [mm ²]
3	0,5 ÷ 0,75	1 ÷ 2,5
3 ÷ 6	0,75 ÷ 1	1 ÷ 2,5
6 ÷ 10	1 ÷ 1,5	1 ÷ 2,5
10 ÷ 16	1,5 ÷ 2,5	1,5 ÷ 4
16 ÷ 25	2,5 ÷ 4	2,5 ÷ 6
25 ÷ 32	4 ÷ 6	4 ÷ 10
32 ÷ 40	6 ÷ 10	6 ÷ 16
40 ÷ 63	10 ÷ 16	10 ÷ 25

3 FUNCTIONING

3.1 Start-up:

- 1) Activate the mains master switch.
- 2) Activate the display cabinet master switch, which is found on the rear protection panel. To introduce the electric power supply to the display cabinet, place the master switch at position "1" (fig. 7 pos. A).

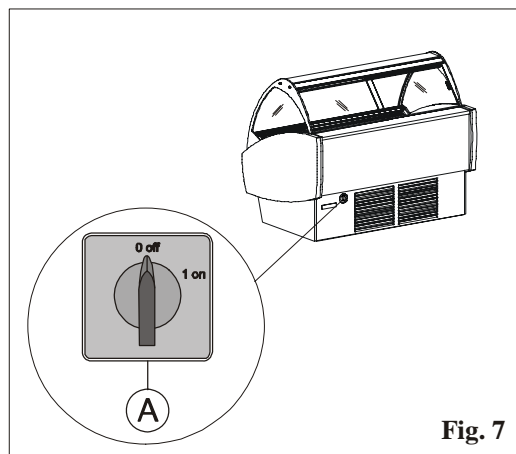

Fig. 7

3.2 Command Console:

The refrigerating plant of the display cabinet is controlled by means of an electronic console. The electronic console consists of:

- 1) Keyboard
- 2) Control board

3.3 Keyboard



T640: horizontal keyboard with 6 keys (185x38mm).



To visualise or change the set point. When programming this button is used to select a parameter or to confirm a value.



This button is used during programming for going through the parameter codes or for increasing their value.



This button is used during programming for going through the parameter codes or decreasing their value.



Keep this button pressed for 3 seconds to start the manual defrosting cycle.













Use this button to turn the display cabinet lights on and off.



Turn the instrument on and off.



3.4 The meaning of the leds

There are a series of luminous points on the display, the meaning of which you will find in the table below:

LED	MODE	Function
	ON	Compressor on
	FLASHING	Programming phase (flashing with LED )
	ON	Ventilator and evaporator active
	FLASHING	Programming phase (flashing with LED )
	ON	Defrosting active
	FLASHING	Dripping time underway
	ON	Keyboard in "ALL" mode
	FLASHING	Keyboard in RVD mode (remote control)
	ON	ALARM SIGNAL - In the "Pr2" programme it indicates that the parameter is also present in "Pr1"

3.5 How to visualise and change the set point



1. Press the SET key and release it to see the set point: you will visualise the set point immediately.
2. To change the set point press the SET key and keep it pressed for 3 seconds: the led will flash  ;
3. To change the value activate  and .
4. To memorise the new set point, press the SET key or wait 15 seconds to exit the programming feature.

3.6 How to set up a manual defrosting cycle



1. Press the DEF key and keep it pressed for more than 2 seconds.

3.7 The ON/OFF Function



By pressing the **ON/OFF** key the instrument will show "OFF".

In this configuration the loads of all of the regulations will be deactivated. To turn the instrument back ON press the **ON/OFF** key again.

The OFF condition allows for the exclusion of the instrument from monitoring without generating any type of alarm.

N.B. The LIGHT key remains active in the OFF position.

3.8 Local Alarms

MESSAGE	CAUSE	STATE OF OUTPUTS
“ P1 ”	Thermostat probe failure	Output according to “ Con “ and “ COF “ parameters
“ HA “	High temperature alarm	Unchanged
“ LA “	Low temperature alarm	Unchanged
“ EE ”	Memory anomaly	
“ EAL “	Digital input alarm	Unchanged
“ BAL ”	Blockage alarm from digital input	Regulation outputs deactivated
“ rtc “	Clock alarm	Unchanged

3.9 Automatic defrosting

The display cabinet is complete with an automatic “pause” defrosting system that allows for rapid elimination of ice formations on the evaporator fins. The automatic defrosting process is set in the standard configuration every 8 hours.

3.10 Stopping the Machine:

To stop the plant act on switch (A), which is found behind the rear protection panel. Position the master switch at “0” (fig. 7 pos. A) disconnecting the display cabinet power supply.

4 PRALINE (OPTIONAL)

4.1 Humidity control



To display and modify target set point. In programming mode it selects a parameter or confirm an operation.

SET To switch the instrument ON/OFF: if the function is enabled (par. onF=Yes), by pressing the SET key for more than 4 sec the controller is switched OFF. To switch the instrument ON again press the SET key.

▲ UP In programming mode it browses the parameter codes or increases the displayed value.

▼ DOWN In programming mode it browses the parameter codes or decreases the displayed value.

Key combinations:

▲ + ▼ To lock or unlock the keyboard

SET + ▼ To enter in programming mode

SET + ▲ To return to the room temperature display

4.2 Use of Leds

A series of light points on the front panels is used to monitor the loads controlled by the instrument. Each LED function is described in the following table:

LED	MODE	Function
	ON	Output relay enabled
LED 1	FLASHING	Programming phase (flashing with LED 2)
LED 2	FLASHING	Programming phase (flashing with LED 1)
E.S.	ON	Energy saving activated by digital input
	ON	ALARM signal In programming "Pr2" indicates the parameter is also present in "Pr1"

4.3 To see and change the Set Point

- SET
1. Push and release the SET key to see the set point value: The value of the set point will be displayed.
 2. Hold pushed the SET key for 3 sec to change the set point value: the LED 1 & 2 start blinking;
 3. To change the set value push the ▼ or ▲ arrows within 10 sec.
 4. To memorise the new set point value push the SET key again or wait 10 sec.

4.4 Alarm signals

MESSAGE	CAUSE	OUTPUTS
"PFo"	Probe broken or absence	Alarm output ON; Output according to parameter "So1"
"PFc"	Probe short circuited	Alarm output ON; Output according to parameter "So1"
"HA"	Maximum alarm	Alarm output ON; Other outputs unchanged
"LA"	Minimum alarm	Alarm output ON; Other outputs unchanged
"EAL"	External alarm	Output unchanged
"BAL"	Serious external alarm	Output OFF

5 MAINTENANCE

5.1 Preliminary Operations:

Before carrying out any maintenance or cleaning the electric power supply must be disconnected by deactivating the plant master switch regarding the room where the display cabinet is positioned.

5.2 Cleaning the condenser:

The deposit of dust and dirt in general on the condenser fins (air) reduces the efficiency of the plant until functioning is prevented and causing damage to the compressor. It is therefore

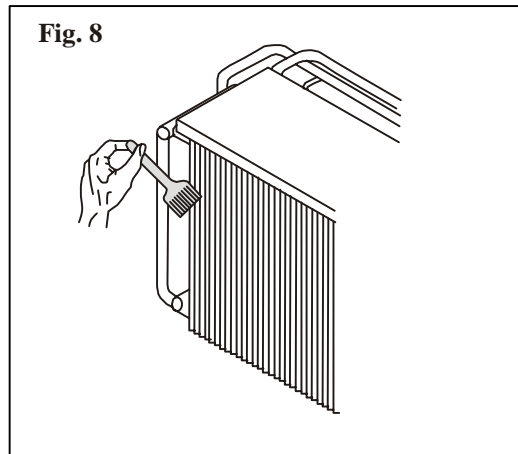

absolutely necessary to periodically clean the condenser (every 20-30 days) as indicated below:

- Disconnect the electric power supply;
- Remove the rear metal grid;
- Remove the dust and dirt present on the condenser fins using a brush or suction device (fig. 8)
- Do not use stiff or metal objects to clean the condenser as they could damage it.

5.3 Periodical defrosting:

For optimal functioning of the display cabinet, it is recommended to perform prolonged defrosting, shutting the display cabinet down for at least 12 hours, by deactivating the electric power supply switch (A) positioned on the rear protection panel of the display cabinet (fig. 7).

5.4 General Cleaning:

- **Steel surface:** Clean using a sponge or damp cloth, using water and neutral detergents, rinse and dry using a soft cloth.
- **Wooden surface:** Clean using a sponge or damp cloth, using water and neutral detergents, rinse and dry using a soft cloth.
- **Glass surface:** Clean using a sponge or damp cloth, using water and neutral detergents, rinse and dry using a soft cloth.

6 PRACTICAL TROUBLESHOOTING GUIDE

1) Temperature of the display area not low enough

PROBABLE CAUSE	PROBABLE SOLUTION
Condenser blocked by dust or other.	Clean the condenser as indicated in point 4.2 Remove everything that obstructs regular air flow to the condenser.
The fans do not function and/or their blades are damaged.	Request after-sales service for replacement
The display cabinet is exposed to air currents or direct sunlight	The display cabinet does not function in these conditions; remove the display cabinet from the air currents and/or direct sunlight
Thermostat does not function correctly. With refrigerant system functioning perfectly the thermostat maintains a higher temperature than that set.	Call the after-sales service.
There is no regular chilled air flow (the “blade of air”) on the ice cream.	Check the air circuit (fan area, area below the evaporator) and remove any obstructions to the circulation of cold air.
No water.	Check that there is flow of water; if so, call a technician due to possible breakage of the water valves or pressure switch or other causes.

2) The water formed by defrosting is not drained (i.e. the water obtained from melting ice during automatic or manual defrosting).

PROBABLE CAUSE	PROBABLE SOLUTION
The water drain pipe that goes from the cold tank to the tank in this water is conveyed (to be made to evaporate) is blocked.	Re-open the drain pipe
The display case is positioned inclined on the ground in a way that the water from defrosting does not go towards the outlet hole.	Level the display cabinet as described in point 2.2. It must be absolutely flat.

3) The compressor never stops or works for long periods of time.

PROBABLE CAUSE	PROBABLE SOLUTION
The room temperature is very high (e.g.: above +32°C).	If the room temperature cannot be lowered (e.g. with air conditioner) the compressor must work almost continuously.
Air condenser blocked.	Clean the condenser as indicated in point 4.2
The thermostat is fixed at a room temperature that is too low.	Adjust the thermostat to a higher temperature, as indicated in point 3.5
The fans are at a standstill.	Call the after-sales service to identify the cause and to replace them if necessary

4) The display cabinet does not work

PROBABLE CAUSE	PROBABLE SOLUTION
The plug is not inserted into the socket.	Insert the plug (see point 2.6)
Any automatic switch tripped.	Re-insert the automatic switch.
Display cabinet master switch open.	Close the display cabinet master switch (see point 3.1)

5) The light does not work

PROBABLE CAUSE	PROBABLE SOLUTION
Light switch not closed.	Close the light switch
The fluorescent bulb is not inserted correctly into the socket.	Insert the bulb correctly.
The bulb has burned out.	Replace the bulb
The “starter” is finished.	Replace the “starter”

7 ELECTRICAL DIAGRAMS

The following electrical diagrams will have to be used by qualified personnel on the basis of the current regulations in vigour in the country of sale.

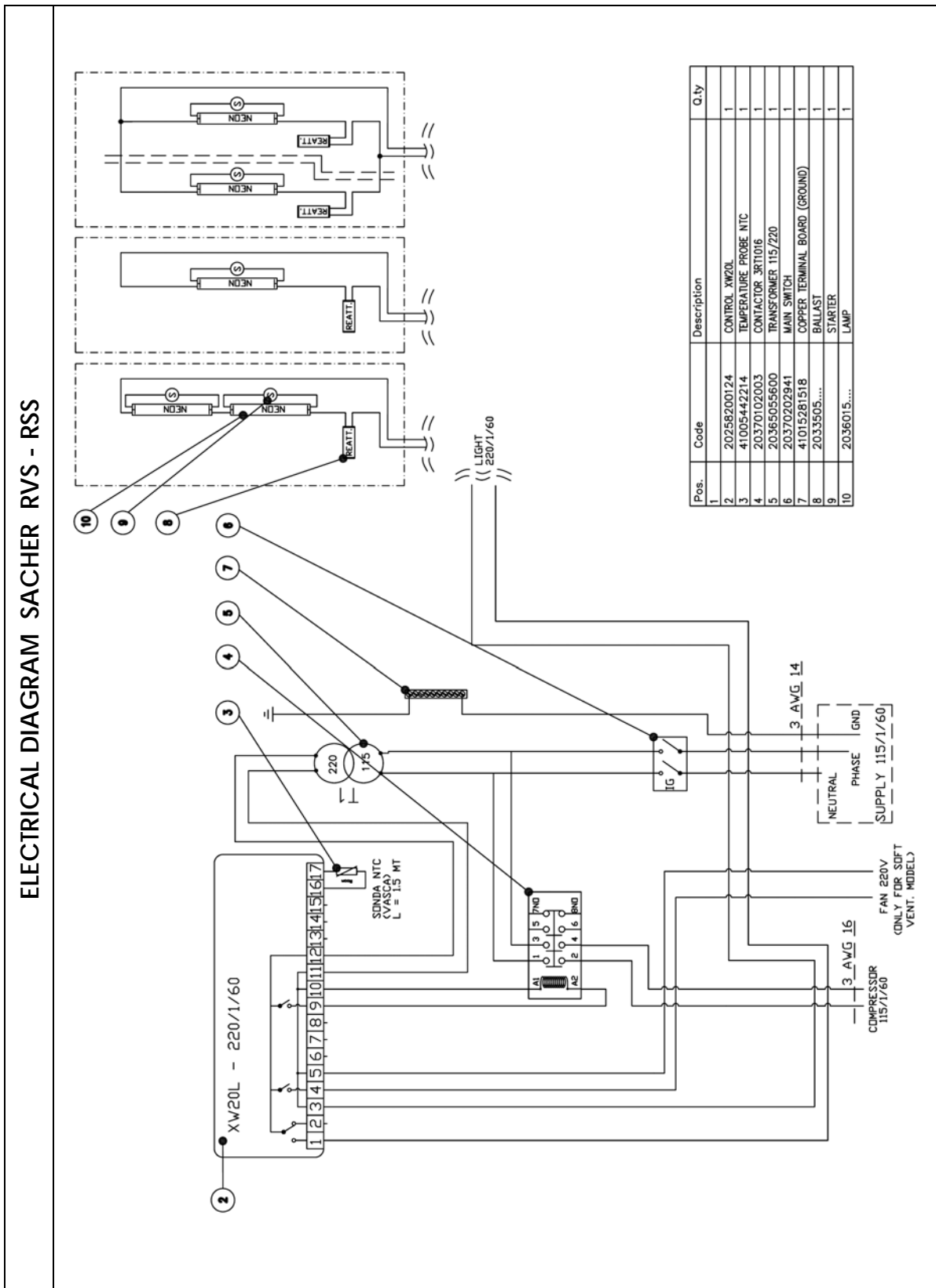

8 **REFRIGERATOR PLANT DIAGRAM**

REFRIGERATOR PLANT DIAGRAM SACHER RVS

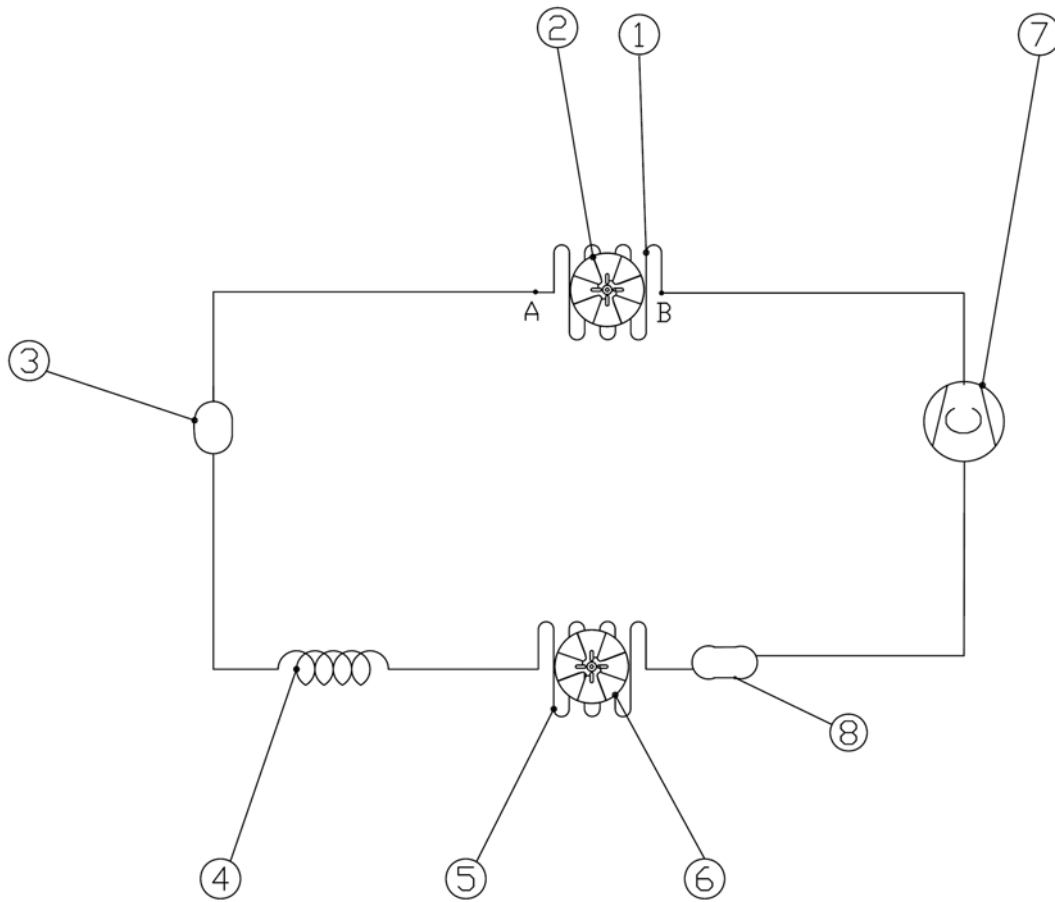

Pos.	Description	Q.ty
1	Condenser	1
2	Condenser fan	1
3	Filter	1
4	Capillary	1
5	Evaporator	1
6	Evaporator fan	1
7	Compressor	1
8	Boiler	1

REFRIGERATOR PLANT DIAGRAM SACHER RSS

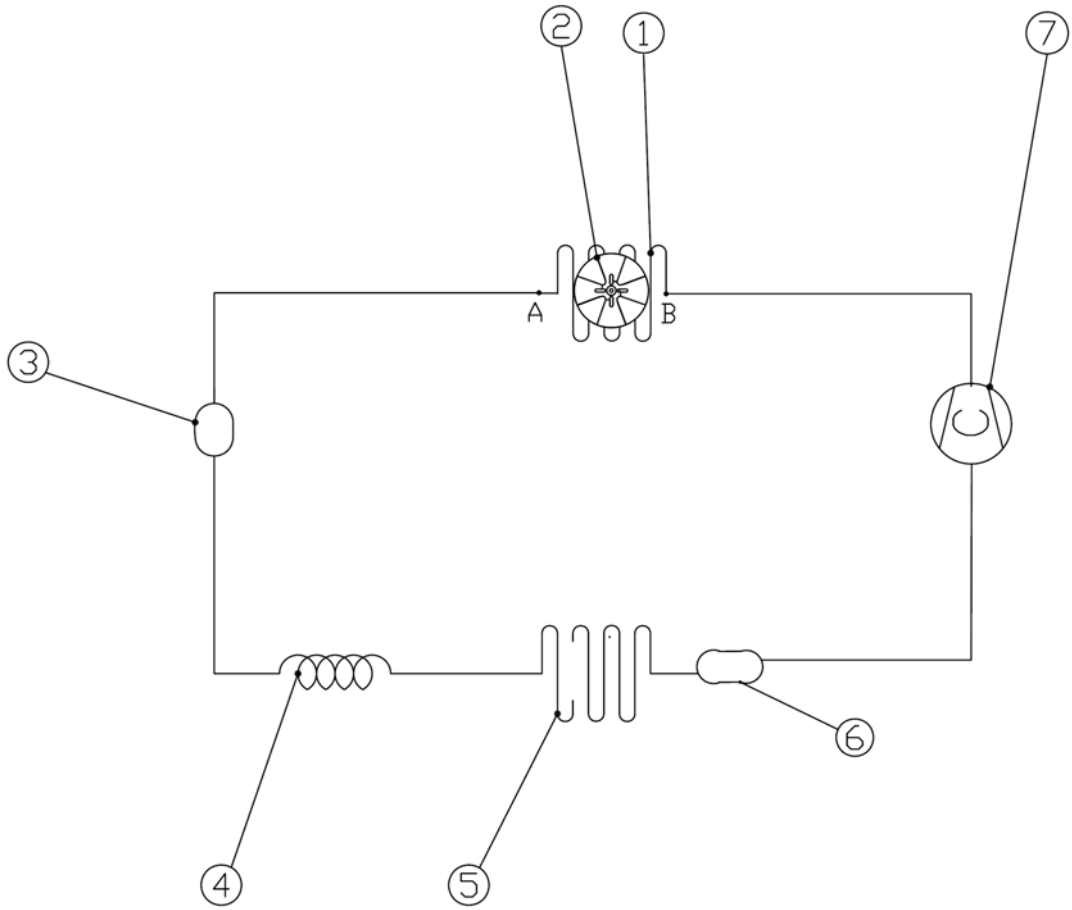

Pos.	Description	Q.ty
1	Condenser	1
2	Condenser fan	1
3	Filter	1
4	Capillary	1
5	Evaporator	1
6	Boiler	1
7	Compressor	1